

Wireless Multifunctional Control Box

R831B User Manual

Table of Contents

1. Introduction.....	2
2. Appearance.....	3
3. Features	4
4. Set up Instruction	4
5. Data Report	5
5.1 Example of ReportDataCmd.....	6
5.2 Example of ConfigureCmd.....	7
5.3 Example of NetvoxLoRaWANRejoin.....	9
6. Installation.....	10
7. Important Maintenance Instruction	11

1. Introduction

R831B is a high-reliability switch control device which is a Class C device of netvox based on the LoRaWAN open protocol. The device is compatible with LoRaWAN protocol. R831B is a device used to control the switch and is mainly used for electrical curtain, garage door, and so on.

LoRa Wireless Technology

LoRa is a wireless communication technology famous for its long-distance transmission and low power consumption. Compared with other communication methods, LoRa spread spectrum modulation technique greatly extend the communication distance. It can be widely used in any use case that requires long-distance and low-data wireless communications. For example, automatic meter reading, building automation equipment, wireless security systems, industrial monitoring. It has features like small size, low power consumption, long transmission distance, strong anti-interference ability and so on.

LoRaWAN

LoRaWAN uses LoRa technology to define end-to-end standard specifications to ensure interoperability between devices and gateways from different manufacturers.

2. Appearance

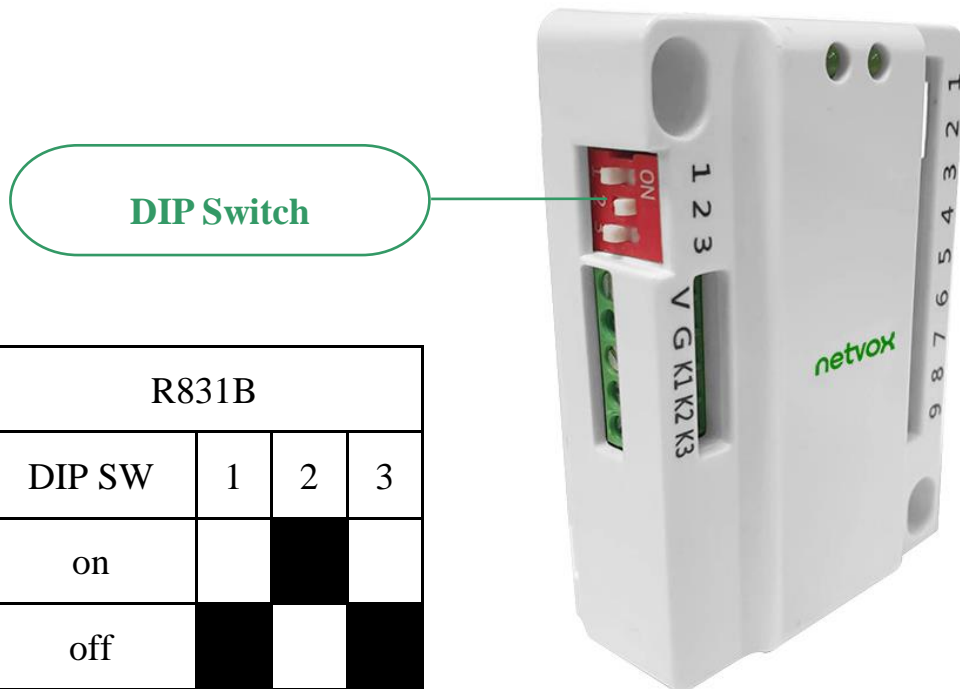
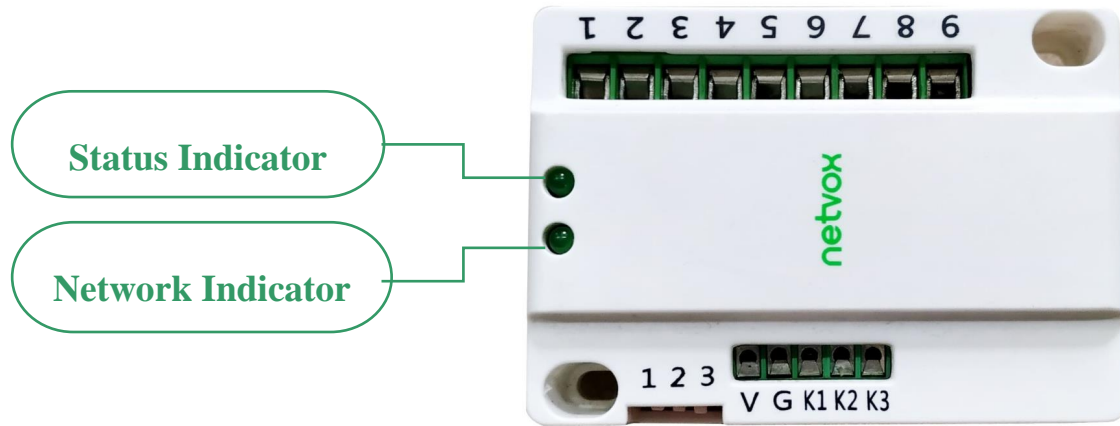

R831B			
DIP SW	1	2	3
on			
off			

1	Port 1
2	Port 2
3	Port 3
4	Port 4
5	Port 5
6	Port 6
7	Port 7
8	GND
9	12V

1~3	DIP Switch (Change R831 series mode)
V	3.3V
G	GND
K1	Local switch-Forward
K2	Local switch-Reverse
K3	Local switch-Stop



3. Features

- SX1276 wireless communication module
- Compatible with LoRaWAN™ Class C
- Frequency hopping spread spectrum
- Configuration parameters can be configured via a third-party software platform, data can be read and alerts can be set via SMS text and email (optional)
- Applicable to third-party platforms: Actility/ThingPark, TTN, MyDevices/Cayenne
- Improved power management for longer battery life

Note: Please visit http://www.netvox.com.tw/electric/electric_calc.html for detailed information of battery lifespan.

(1) The actual range may vary depending on the environment.

(2) Battery life is determined by sensor reporting frequency and other variables.

4. Set up Instruction

On/Off

Power On	External 12V power supply
Turn On	After plug the power, the status indicator will stay on, it means the boot is successful.
Restore To Factory Setting	Press and hold the function key for 5 seconds till the status indicator flashes 20 times.
Power Off	Remove power
Note:	Press and hold the function key then power on, it will enter engineering mode

Network Joining

Never Joined The Network	Turn on the device, and it will search for the network to join. The network indicator stays on: joins the network successfully The network indicator stays off : fail to join the network
Had Joined The Network (Not Restore To Factory Setting)	Turn on the device, and it will search for the previous network to join. The network indicator stays on: joins the network successfully The network indicator stays off : fail to join the network
Fail To Join The Network	Suggest checking the device registration information on the gateway or consulting your platform server provider if the device fails to join the network.

Function Key

Press the function key and hold the pressing for 5 seconds	The device will be set to default and turned off The status indicator light flashes 20 times: success The status indicator light remains off: fail
Press the function key once	The device is in the network: the status indicator light flashes once and sends a report The device is not in the network: the status indicator light remains off
Press K1 local switch	Motor forward
Press K2 local switch	Motor reverse
Press K3 local switch	Motor stop

*The specific key refers to the physical appearance

5. Data Report

The device will immediately send a version packet and a report packet with the motor status.

The device sends data in the default configuration before any configuration is done.

Default setting:

MaxTime: Max Interval = 900s

MinTime: Min Interval = 2s (The current power state will be checked every Min Interval by default.)

RejoinCheckPeriod = 2 (hr)

RejoinThreshold = 3 (times)

Note:

- (1) The report interval of the device will be programmed based on the default firmware which may vary.
- (2) The interval between two reports must be the MinTime.
- (3) If there are special customized shipments, the setting will be changed according to customer's requirements.
- (4) Please visit Netvox LoRaWAN Application Command document and Netvox Lora Command Resolver

<http://cmddoc.netvoxcloud.com/cmddoc> to resolve uplink data.

Data report configuration and sending period are as following:

Min Interval (Unit: second)	Max Interval (Unit: second)	Reportable Change	Current Change \geq Reportable Change	Current Change $<$ Reportable Change
Any number between 1~65535	Any number between 1~65535	Can not be 0	Report per Min Interval	Report per Max Interval

5.1 Example of ReportDataCmd

Fport: 0x06

Bytes	1	1	1	Var (Fix=8 Bytes)
	Version	DeviceType	ReportType	NetvoxPayLoadData

Version– 1 byte –0x01——the Version of NetvoxLoRaWAN Application Command Version

DeviceType– 1 byte – Device Type of Device

ReportType – 1 byte –the presentation of the NetvoxPayLoadData, according to the devicetype

NetvoxPayLoadData– Var (Fix =8bytes)

Tips

1. Battery Voltage:

If the battery is equal to 0x00, it means that the device is powered by a DC power supply.

2. Version Packet:

When Report Type=0x00 is the version packet, such as 01B3000A02202401150000, the firmware version is 2024.01.15.

3. Data Packet:

When Report Type=0x01 is data packet

Device	DeviceType	ReportType	NetvoxPayLoadData			
R831B	0xB3	0x00	SoftwareVersion (1Byte) Eg.0x0A—V1.0	HardwareVersion (1Byte)	DateCode (4Bytes, eg 0x20170503)	Reserved (2Bytes, fixed 0x00)
		0x01	MotorStatus (1Byte, OFF_0x00, ON_0x01)		Reserved(7Bytes, fixed 0x00)	

Uplink: 01B3010000000000000000

1st (01): Version

2nd (B3): DeviceType

3rd (01): ReportType

4th (00): MotorStatus – OFF

5th –11th (00000000000000): Reserved

5.2 Example of ConfigureCmd

FPort: 0x07

Bytes	1	1	Var(Fix =9 Bytes)
	CmdID	DeviceType	NetvoxPayLoadData

CmdID– 1 byte

DeviceType– 1 byte – Device Type of Device

NetvoxPayLoadData– var bytes (Max=9bytes)

Description	Device	CmdID	Device Type	NetvoxPayLoadData		
Off	R831B	0x90	0xB3	Reserved (9Bytes, Fixed 0x00)		
On		0x91		Reserved (9Bytes, Fixed 0x00)		
Toggle		0x92		Reserved (9Bytes, Fixed 0x00)		
ReadCurrentStatus		0x94		Reserved (9Bytes, Fixed 0x00)		
Stop		0x95		Reserved (9Bytes, Fixed 0x00)		
ConfigReportReq		0x01		MinTime (2bytes Unit: s)	MaxTime (2bytes Unit: s)	Reserved (5Bytes, Fixed 0x00)
ConfigReportRsp		0x81		Status (0x00_success)	Reserved (8Bytes, Fixed 0x00)	
ReadConfigReportReq		0x02		Reserved (9Bytes, Fixed 0x00)		
ReadConfigReportRsp		0x82		MinTime (2bytes Unit: s)	MaxTime (2bytes Unit: s)	Reserved (5Bytes, Fixed 0x00)
SetSwitchTypeReq		0x03		SwitchType(1byte) 0x00_Toggle 0x01_Momentary	Reserved (8Bytes, Fixed 0x00)	
SetSwitchTypeRsp		0x83		Status (0x00_success)	Reserved (8Bytes, Fixed 0x00)	
GetSwitchTypeReq		0x04		Reserved (9Bytes, Fixed 0x00)		
GetSwitchTypeRsp		0x84		SwitchType(1byte) 0x00_Toggle 0x01_Momentary	Reserved (8Bytes, Fixed 0x00)	

Max Time and Min Time setting

(1) Command Configuration:

MinTime = 1min 、 MaxTime = 1min

Downlink: 01B3003C003C0000000000

Response: 81B3000000000000000000 (Configuration success)

81B301000000000000000000 (Configuration failure)

(2) Read Configuration:

Downlink: 02B3000000000000000000

Response: 82B3003C003C0000000000 (Current configuration)

Motor Switch Configuration

(3) Motor Reverse

Downlink: 90B3000000000000000000

(4) Motor Advance

Downlink: 91B3000000000000000000

(5) Switch Motor State (Change from advance to reverse or from reverse to advance)

Downlink: 92B3000000000000000000

(6) Motor Stop

Downlink: 95B3000000000000000000

Switch Type Configuration

(7) Setting switch type is tact type switch

Downlink: 03B3010000000000000000

Response: 83B3000000000000000000 (Configuration success)

(8) Confirm switch type

Downlink : 04B3000000000000000000

Response : 84B3010000000000000000 (The switch type is tact type)

5.3 Example of NetvoxLoRaWANRejoin

(NetvoxLoRaWANRejoin command is to check if the device is still in the network. If the device is disconnected, it will automatically rejoin back to the network.)

Fport: 0x20

CmdDescriptor	CmdID (1 Byte)	Payload (5 Bytes)	
SetNetvoxLoRaWANRejoinReq	0x01	RejoinCheckPeriod (4 Bytes, Unit: 1s 0xFFFFFFFF Disable NetvoxLoRaWANRejoinFunction)	RejoinThreshold (1 Byte)
SetNetvoxLoRaWANRejoinRsp	0x81	Status (1 Byte, 0x00_success)	Reserved (4 Bytes, Fixed 0x00)
GetNetvoxLoRaWANRejoinReq	0x02	Reserved (5 Bytes, Fixed 0x00)	
GetNetvoxLoRaWANRejoinRsp	0x82	RejoinCheckPeriod (4 Bytes, Unit: 1s)	RejoinThreshold (1 Byte)

(1) Configure parameters

RejoinCheckPeriod = 60min (0x00000E10); RejoinThreshold = 3 times (0x03)

Downlink: 0100000E1003

Response: 810000000000 (configuration succeed)

810100000000 (configuration fail)

(2) Read configuration

Downlink: 020000000000

Response: 8200000E1003

Note: a. Set RejoinCheckThreshold as 0xFFFFFFFF to stop the device from rejoining the network.

b. The last configuration would be kept as user reset the device back to the factory setting.

c. Default setting: RejoinCheckPeriod = 2 (hr) and RejoinThreshold = 3 (times)

6. Installation

This product does not have a waterproof function. After joined the network, please place it indoors.

The wiring diagram as follow below:

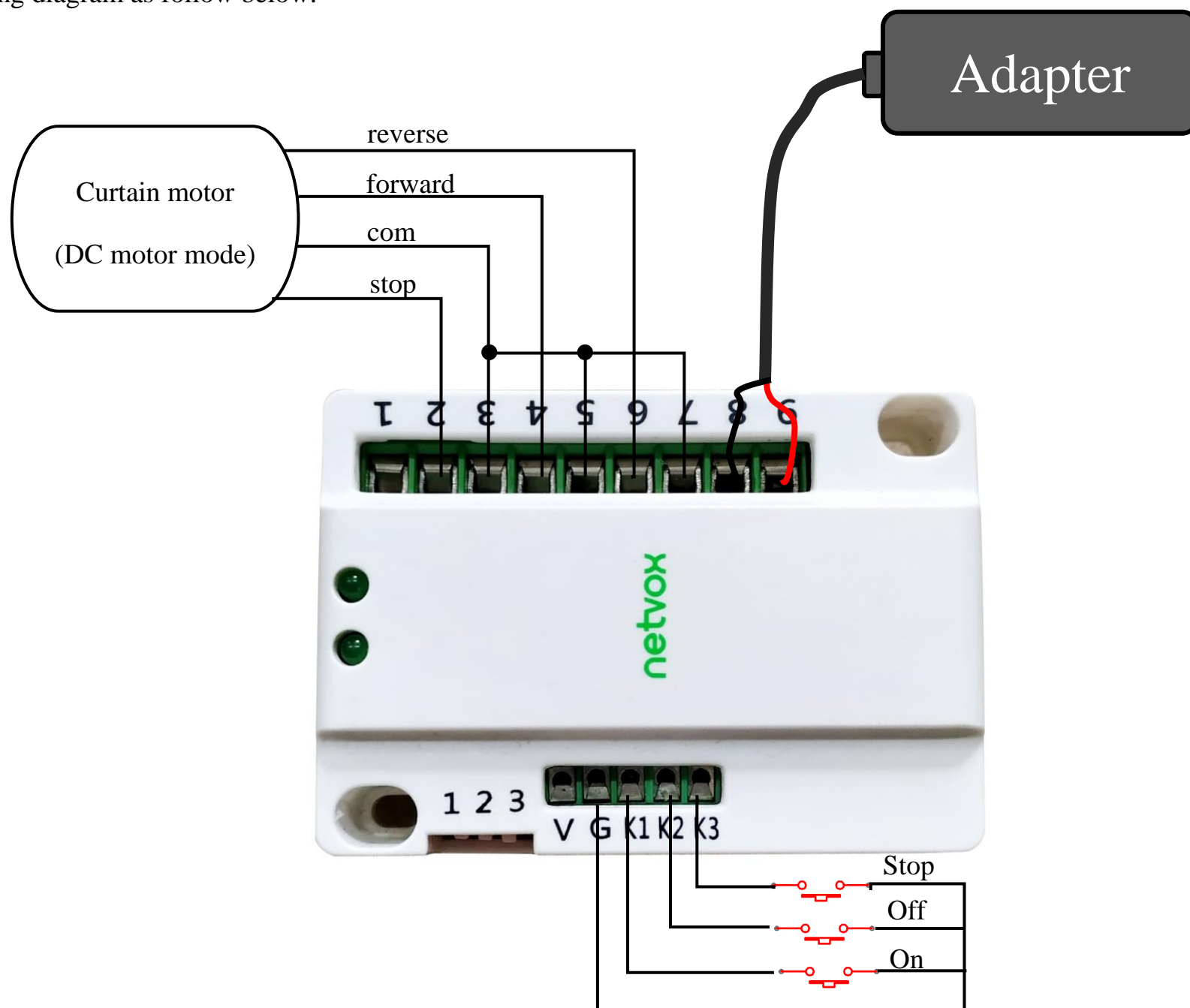

Instructions on switching the operating mode (If users do not strictly follow the manual connection, it may damage the product.)

R831 has four operating modes corresponding to the three keys of the DIP switch.

Toggle the switch and power on again to switch the corresponding state.

(If the DIP switch is not correctly toggled, the network lights and status lights will flash alternately, users need to dial power down and power on again.)

(1) **R831B** - button mode: Toggle the DIP switch 2

This mode has three relays involved in the operation which are respectively for on /off / stop.

(2) **R831C** - relay mode: Toggle the DIP switch 3

In this mode, the external dry contact can directly control the on / off of the local relay.

(3) **R831D** - relay mode: Toggle the DIP switches 1 and 2

In this mode, the external dry contact does not directly control the on/off of the local relay but reports the dry contact status and relay status.

R831B Local switch control

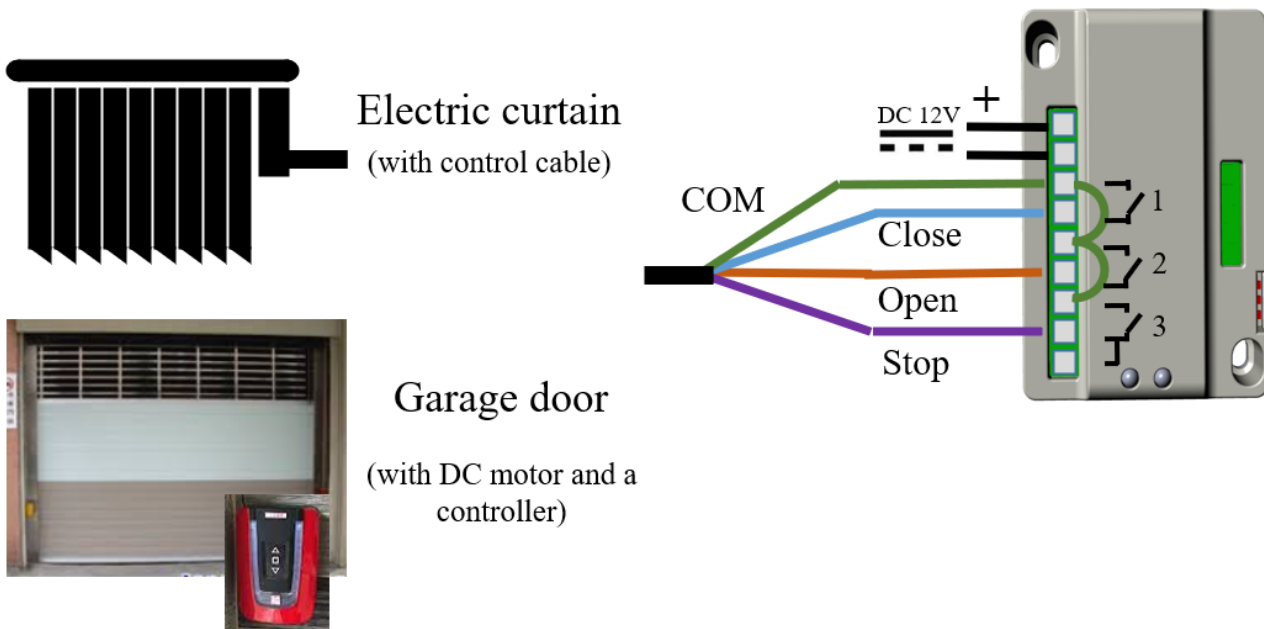
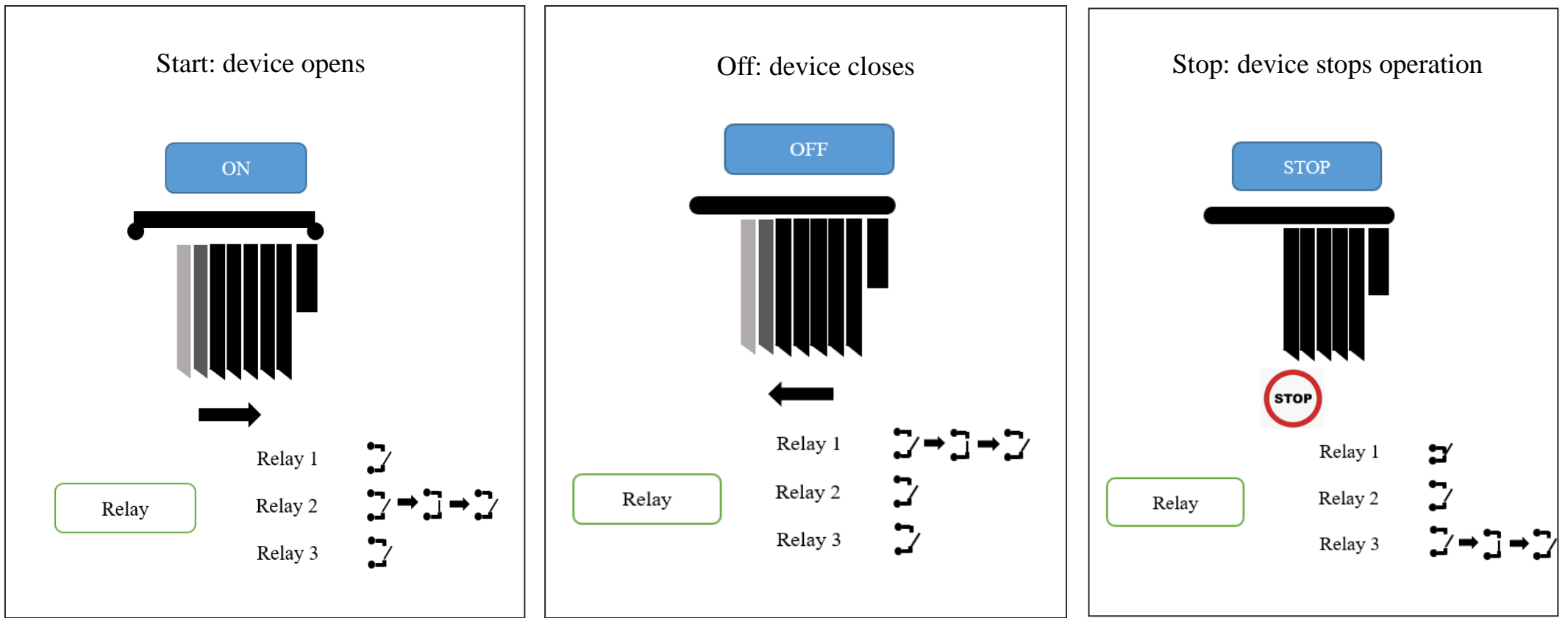

1. Device type:
electric curtain and garage door
2. Control PORT:
controlled by dry contact (could be connected with switch)

7. Important Maintenance Instruction

Kindly pay attention to the following to achieve the best maintenance of the product:

- Keep the equipment dry. Rain, moisture, and various liquids or water may contain minerals that can corrode electronic circuits. In case the device is wet, please dry it completely.
- Do not use or store in dusty or dirty areas. This way can damage its detachable parts and electronic components.
- Do not store in an excessively warm place. High temperatures can shorten the life of electronic devices, destroy batteries, and deform or melt some plastic parts.
- Do not store in excessively cold places. Otherwise, when the temperature rises to normal temperature, moisture will form inside which will destroy the board.
- Do not throw, knock, or shake the device. Treating equipment roughly can destroy internal circuit boards and delicate structures.
- Do not wash with strong chemicals, detergents, or strong detergents.
- Do not paint the device. Smudges can make debris block detachable parts and affect normal operation.
- Do not throw the battery into the fire to prevent the battery from exploding. Damaged batteries may also explode.

The instructions are applied to your device, battery, and accessories. If any device is not working properly, please bring it to the nearest authorized service provider for repair.