

Wireless RS232 Adapter

User Manual

Copyright©Netvox Technology Co., Ltd.

This document contains proprietary technical information which is the property of NETVOX Technology. It shall be maintained in strict confidence and shall not be disclosed to other parties, in whole or in part, without written permission of NETVOX Technology. The specifications are subject to change without prior notice.

Table of Content

1. Introduction.....	2
2. Appearance.....	3
3. Main Characteristic.....	3
4. Set Up Instruction	4
5. Data Report	5
6. Installation	8
7. Important Maintenance Instruction	9



1. Introduction

R718PDA is a Class C type device based on the LoRaWAN open protocol of Netvox and is compatible with the LoRaWAN protocol.

R718PDA supports serial port transparent transmission. It can send the read commands to other sensors supporting RS-232 protocol according to the configured period, and the information returned by the other sensors will be directly reported to the gateway. It supports up to 128 bytes of data (depending on the current communication rate).

The serial port transparent transmission only supports RS-232 protocol.

LoRa Wireless Technology:

LoRa is a wireless communication technology dedicated to long distance and low power consumption. Compared with other communication methods, LoRa spread spectrum modulation method greatly increases to expand the communication distance. Widely used in long-distance, low-data wireless communications. For example, automatic meter reading, building automation equipment, wireless security systems, industrial monitoring. Main features include small size, low power consumption, transmission distance, anti-interference ability and so on.

LoRaWAN:

LoRaWAN uses LoRa technology to define end-to-end standard specifications to ensure interoperability between devices and gateways from different manufacturers.

2. Appearance

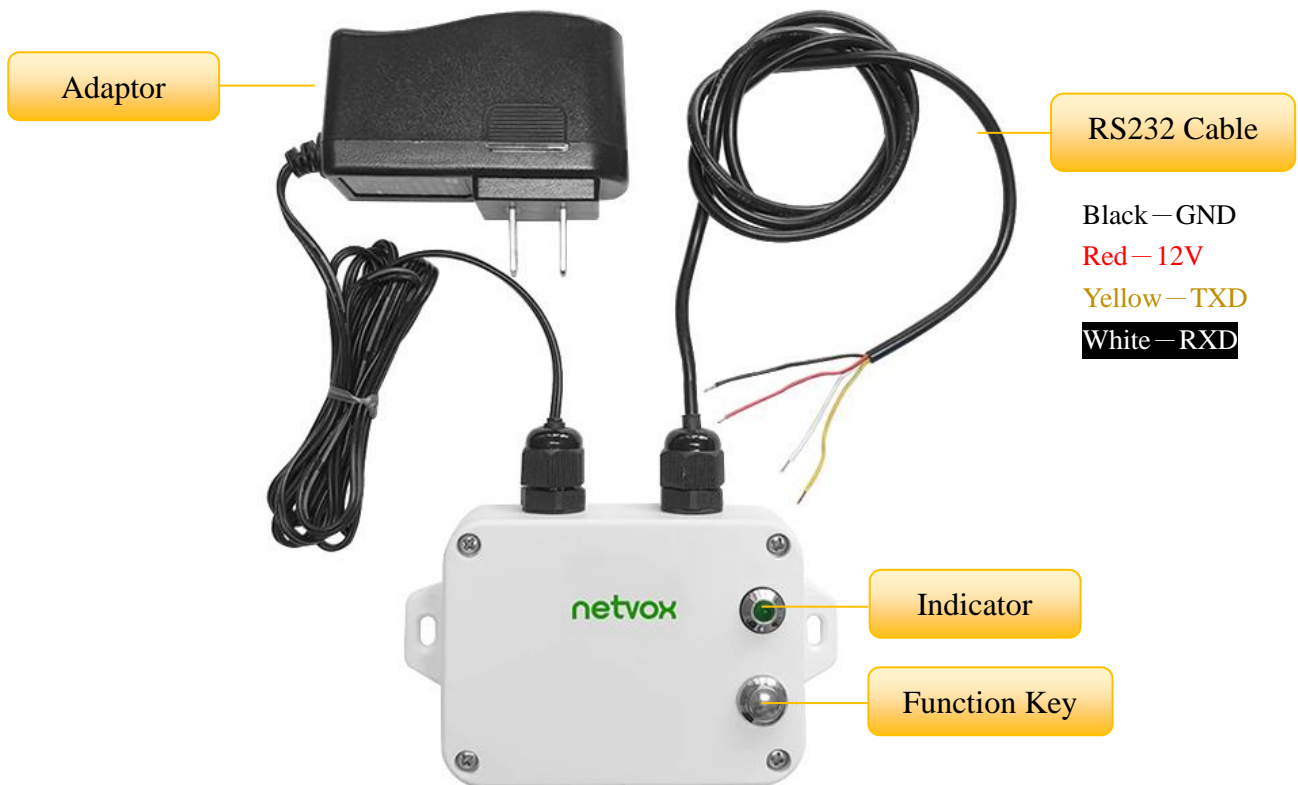

3. Main Characteristic

- Adopt SX1276 wireless communication module
- External DC 12V power supply (R718PDA is powered by an external RS232 device)
- Protection level IP65/IP67 (option)
- The base is attached with a magnet that can be attached to a ferrous object
- RS232 serial port transparent transmission
- Compatible with LoRaWAN™ Class C
- Frequency hopping spread spectrum
- Configuring parameters and reading data via third-party software platforms, and set alarms via SMS text and email (optional)
- Applicable to third-party platforms: Actility/ThingPark, TTN, MyDevices/Cayenne

4. Set Up Instruction

On/Off

Power On	External DC12V power supply
Turn On	DC12V power supply, the green indicator flashing once means turn on successfully.
Turn Off (Restore to Factory Setting)	Press and hold the function key for 5 seconds till the green indicator flashes 20 times.
Power Off	Remove power
Note	<ol style="list-style-type: none"> 1. In the first 5 seconds after power on, the device will be in engineering test mode. 2. On/off interval is suggested to be about 10 seconds to avoid the interference of capacitor inductance and other energy storage components.

Network Joining

Never Joined The Network	<p>Turn on the device to search the network.</p> <p>The green indicator stays on for 5 seconds: success</p> <p>The green indicator remains off: fail</p>
Had Joined The Network (Not Restore to Factory Setting)	<p>Turn on the device to search the previous network.</p> <p>The green indicator stays on for 5 seconds: success</p> <p>The green indicator remains off: fail</p>
Fail to Join The Network	Suggest to check the device verification information on the gateway or consult your platform server provider.

Function Key

Press and Hold for 5 Seconds	<p>Restore to factory setting / Turn off</p> <p>The green indicator flashes for 20 times: success</p> <p>The green indicator remains off: fail</p>
Press Once	<p>The device is in the network: 87+ReceiveData (ReceiveData is the most recently received data) format packet</p> <p>The device is not in the network: the green indicator remains off</p>

Baud Rate Configuration

Serial Transmission Rate Default Value	9600
Configuration Method	Issue instructions through LORANWAN
Serial Transmission Rate Option	00 Baudrate = 115200; 01 Baudrate = 57600; 02 Baudrate = 38400; 03 Baudrate = 28800; 04 Baudrate = 19200; 05 Baudrate = 9600; 06 Baudrate = 4800; 07 Baudrate = 2400

5. Data Report

The device will send a version package report immediately after powered on.

The device has no operation before any configuration is done.

The device sends instructions through LORAWAN to configure the data that needs to be sent through RS232, and it reports the data that RS232 receives to the gateway at the same time.

The device sends instructions through LORAWAN to configure the time to periodically send the data.

When RS232 interface of R718PDA receives the serial port data from the RS232 device that it is connected to, it will actively report the received data to the gateway in the format of 87+ReceiveData.

Please refer Netvox LoRaWAN Application Command document and Netvox Lora Command Resolver <http://cmddoc.netvoxcloud.com/cmddoc> to resolve uplink data.

Data Report Cycle Configuration Example

FPort : 0x0A

Description	Device	CmdID	NetvoxPayLoadData
SetPollSensor PeriodReq	R718PDA	0x03	Period (2Byte, Unit: 1s)
SetPollSensor PeriodRsp		0x83	Status (0x00_success)
GetPollSensor PeriodReq		0x04	
GetPollSensor PeriodRsp		0x84	Period (2Byte, Unit: 1s)

(1) Configure the device Period = 30s

Downlink: 03001E

Device Return:

8300 (configuration success)

8301 (configuration failure)

(2) Read the device parameters

Downlink: 04

Device Return: 84001E (current device parameter)

Note:

After SetPollSensorPeriodReq(CmdID:03) sets the periodical sending time to 30 seconds, R718PDA will send the command that is set by SetPollSensorRawCmdReq(CmdID:05) to the connected RS232 device every 30 seconds, and the response content of RS232 device will be reported in the format of 87(CmdID) + ReceiveData.

Data Report Configuration Example:

Description	Device	CmdID	NetvoxPayLoadData
SetPollSensor RawCmdReq	R718PDA	0x05	SensorRawCmd
SetPollSensor RawCmdRsp		0x85	Status (0x00_success)
GetPollSensor RawCmdReq		0x06	
GetPollSensor RawCmdRsp		0x86	SensorRawCmd

(1) Configure the device SensorRawCmd

Downlink: 05112233445566

Device Return:

8500 (configuration success)

8501 (configuration failure)

(2) Read the device SensorRawCmd

Downlink: 06

Device Return: 86112233445566 (device current SensorRawCmd)

Baud Rate Configuration

Description	Device	CmdID	NetvoxPayloadData
SetBaudRateReq	R718PDA	0x08	BaudRateType (1Byte)
SetBaudRateRsp		0x88	Status (0x00_success)
GetBaudRateReq		0x09	
GetBaudRateRsp		0x89	BaudRateType (1Byte)

(1) Configure the device Baud Rate =115200

Downlink: 0800

Device Return:

8800 (configuration success)

8801 (configuration failure)

(2) Read the device Baud Rate parameter

Downlink: 09

Device Return: 8900 (device current parameter)

6. Installation

1. Wireless RS232 Adapter (R718PDA) has the built-in magnet. When installation, it can be attached to the surface of an object with iron conveniently and quickly.

In order to make the device installation more secure, use screws (purchased) to fix the device to the wall or other surface (as the figure below).

Note:

Do not install the device in a metal shielded box or in an environment with other electrical equipment around it to avoid affecting the wireless transmission of the device.

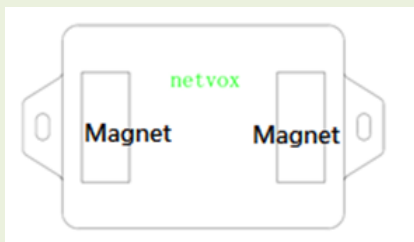

2. The colors of wiring of RS232 serial device are as following:

Yellow: TXD

White: RXD

Black: GND

3. Wireless RS232 Adapter (R718PDA) supports serial port transparent transmission. It can send commands to or read data of the other connected RS232 device according to the configured period. The read information will be directly reported to the gateway.

Wireless RS232 Adapter (R718PDA) can be applied to the device with RS232 serial port.

For example:

- UPS (Uninterruptible power supply)
- Access control
- Hard disk player
- Other devices with RS232 serial port

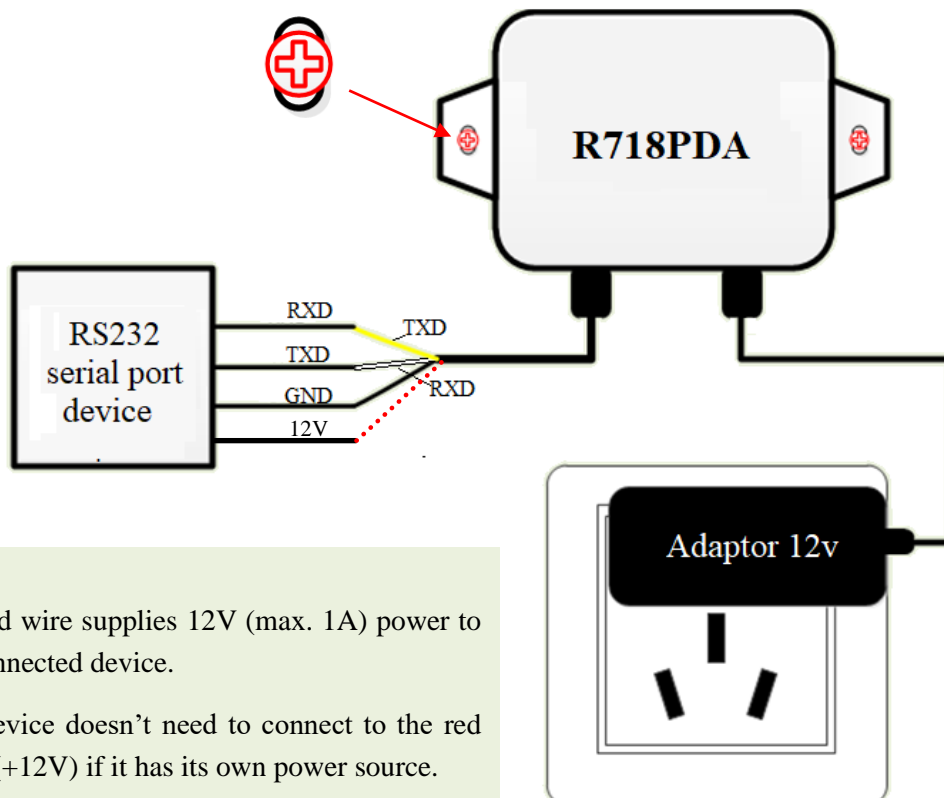

Note:

- (1) The red wire supplies 12V (max. 1A) power to the connected device.
- (2) The device doesn't need to connect to the red wires (+12V) if it has its own power source.

7. Important Maintenance Instruction

Kindly pay attention to the following in order to achieve the best maintenance of the product:

- Keep the equipment dry. Rain, moisture and various liquids or water may contain minerals that can corrode electronic circuits. In case the device is wet, please dry it completely.
- Do not use or store in dusty or dirty areas. This way can damage its detachable parts and electronic components.
- Do not store in excessive heat place. High temperatures can shorten the life of electronic devices, destroy batteries, and deform or melt some plastic parts.
- Do not store in excessive cold place. Otherwise, when the temperature rises to normal temperature, moisture will form inside which will destroy the board.
- Do not throw, knock or shake the device. Treating equipment roughly can destroy internal circuit boards and delicate structures.
- Do not wash with strong chemicals, detergents or strong detergents.
- Do not paint the device. Smudges can make debris block detachable parts up and affect normal operation.
- Do not throw the battery into the fire to prevent the battery from exploding. Damaged batteries may also explode.

All the above suggestions apply equally to your device, batteries and accessories.

If any device is not operating properly.

Please take it to the nearest authorized service facility for repairing.