

Wireless ORP Sensor

Wireless ORP Sensor

R718PA9

User Manual

Copyright©Netvox Technology Co., Ltd.

This document contains proprietary technical information which is the property of NETVOX Technology. It shall be maintained in strict confidence and shall not be disclosed to other parties, in whole or in part, without written permission of NETVOX Technology. The specifications are subject to change without prior notice.

Table of Content

1. Introduction.....	2
2. Appearance	2
3. Main Feature	3
4. Set Up Instruction	4
5. Data Report	5
6. Information about Battery Passivation	6
7. Important Maintenance Instruction.....	7



1. Introduction

R718PA9 is a Class A device based on the LoRaWAN™ protocol of Netvox and is compatible with LoRaWAN protocol.

R718PA9 can be connected with an ORP sensor (RS485) externally and report the ORP value of the solution collected by the device to the corresponding gateway.

LoRa Wireless Technology:

LoRa is a wireless communication technology dedicated to long distance and low power consumption. Compared with other communication methods, LoRa spread spectrum modulation method greatly increases to expand the communication distance. Widely used in long-distance, low-data wireless communications. For example, automatic meter reading, building automation equipment, wireless security systems, industrial monitoring. Main features include small size, low power consumption, transmission distance, anti-interference ability and so on.

LoRaWAN:

LoRaWAN uses LoRa technology to define end-to-end standard specifications to ensure interoperability between devices and gateways from different manufacturers.

2. Appearance

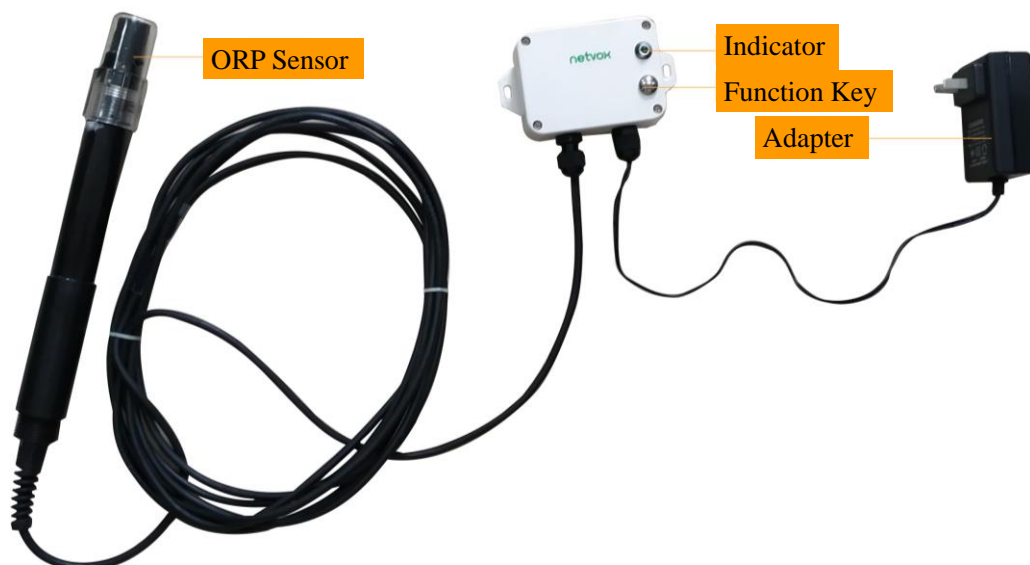

3. Main Feature

- Adopt SX1276 wireless communication module
- RS485 communication
- 12V DC power supply
- ORP sensor detection
- The base is equipped with a magnet that can be attached to the iron object
- Protection level IP65
- Compatible with LoRaWAN™ Class A
- Frequency hopping spread spectrum technology
- Configuring parameters and reading data via the third-party software platforms, and set alarms via SMS text and email (optional)
- Applicable to the third-party platforms: Actility/ ThingPark/ TTN/ MyDevices/ Cayenn

Note:

Battery life is determined by the sensor reporting frequency and other variables, please refer to http://www.netvox.com.tw/electric/electric_calc.html

On this website, users can find battery lifetime for varied models at different configurations.

4. Set Up Instruction

On/Off

Power On	DC12V adapter
Turn On	DC12V power supply, the green indicator flashing once means turn on successfully.
Turn Off (Restore to factory setting)	Press and hold the function key for 5 seconds, and the green indicator flashes 20 times.
Power Off	Remove DC12V adapter
Note	<ol style="list-style-type: none"> 1. On/off interval is suggested to be about 10 seconds to avoid the interference of capacitor inductance and other energy storage components. 2. Five seconds after power on, the device will be in engineering test mode.

Network Joining

Never Join the Network	<p>Turn on the device to search the network.</p> <p>The green indicator keeps on for 5 seconds: success.</p> <p>The green indicator remains off: fail</p>
Had Joined the Network (Not restore to the factory setting)	<p>Turn on the device to search the previous network.</p> <p>The green indicator keeps on for 5 seconds: success.</p> <p>The green indicator remains off: fail.</p>
Fail to Join the Network	Suggest checking the device registration information on the gateway or consulting your platform server provider if the device fails to join the network.

Function Key

Press and Hold for 5 Seconds	<p>Restore to the original setting / turn off</p> <p>The green indicator flashes 20 times: success</p> <p>The green indicator remains off: fail</p>
Press once	<p>The device is in the network: the green indicator flashes once and the device sends a data report</p> <p>The device is not in the network: the green indicator remains off</p>

5. Data Report

After power on, the device will immediately send a version packet report. Then, it will send another report with the data of ORP value **after it is powered on for 20s.**

The device sends data according to the default configuration before any other configuring.

Default setting:

MaxTime: Max Interval=180s (3min)

MinTime: The MinTime configuration is not available. But the software has restriction, MinTime must be configured a number greater than 0.

Note:

- 1.Report interval is based on the factory default.
- 2.R718PA9 reports the ORP value.

The device reported data parsing please refer to
Netvox LoraWAN Application Command document and Netvox Lora Command Resolver

<http://www.netvox.com.cn:8888/cmddoc>

Report Configuration

Description	Device	Cmd ID	Device Type	NetvoxPayLoadData		
ConfigReport Req	R718PA9	0x01	0x57	MinTime (2bytes Unit: s)	MaxTime (2bytes Unit: s)	Reserved (5Bytes, Fixed 0x00)
ConfigReport Rsp		0x81		Status (0x00_success)	Reserved (8Bytes, Fixed 0x00)	
ReadConfig ReportReq		0x02		Reserved (9Bytes, Fixed 0x00)		
ReadConfig ReportRsp		0x82		MinTime (2bytes Unit: s)	MaxTime (2bytes Unit: s)	Reserved (5Bytes, Fixed 0x00)

- (1) Configure R718PA9 device parameter MaxTime = 1min (The MinTime configuration is useless, but it needs to be set greater than 0 because of the software limitation.)

Downlink: 0157000A003C0000000000

Device Return:

81570000000000000000000000000000 (configuration success)

81570100000000000000000000000000 (configuration failure)

- (2) Read R718PA9 device parameter

Downlink: 02570000000000000000000000000000

Device Return:

8257000A003C0000000000 (device current parameter)

6. Information about Battery Passivation

1. R718PA9 has the built-in magnet (as the figure below) which can be attached to the surface of an iron object during installation, which is convenient and quick.

In order to make the installation firmer, please use screws (purchased separately) to fix the device to the wall or other surface (as the figure below).

Note: Do not install the device in a metal shielded box or in an environment surrounded by other electrical equipment to avoid affecting the wireless transmission of the device.

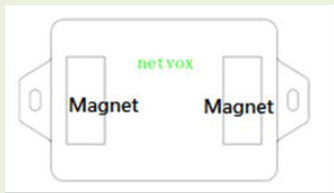

2. R718PA9 regularly reports the data of ORP value according to MaxTime. The default Max Time is 3 minutes.

Note:

MaxTime can be modified by the downlink command, but it is recommended not to set the interval too short.

R718PA9 can be applied to detecting the ORP value of the solution.

Example:

- Water Quality Monitor
- Industrial Sewage Disposal
- Agricultural Irrigation/Aquaculture
- Swimming Pool/Hot Spring

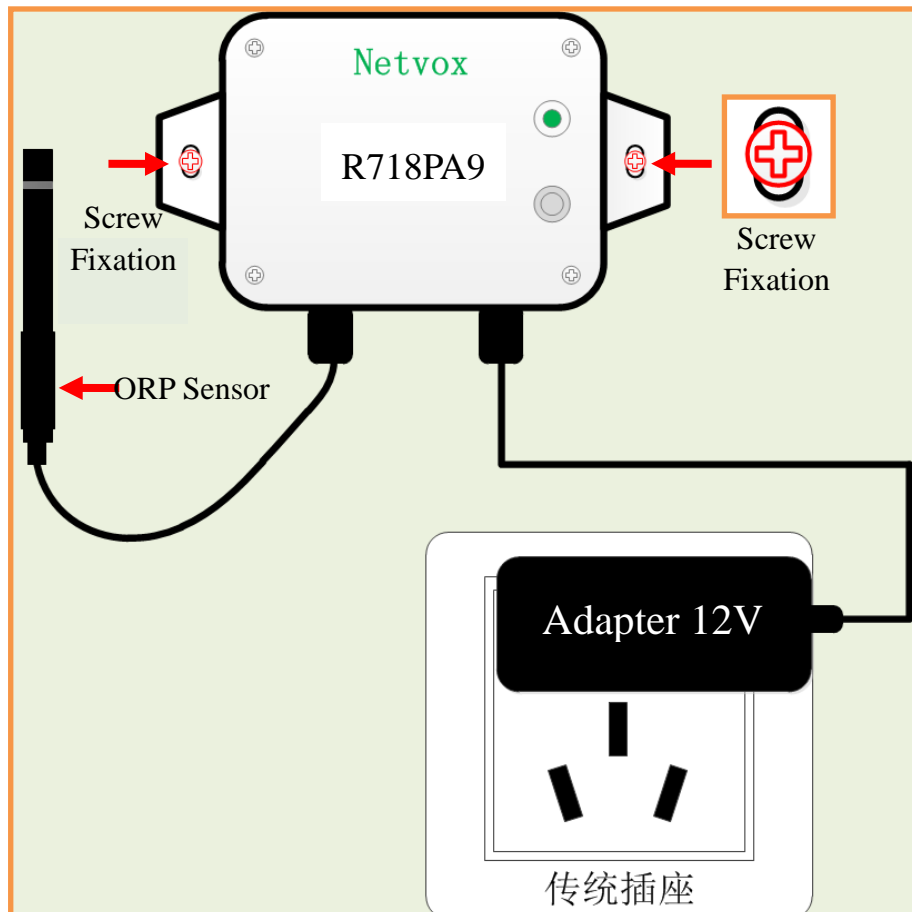

7. Important Maintenance Instruction

Kindly pay attention to the following in order to achieve the best maintenance of the product:

- Keep the equipment dry. Rain, moisture and various liquids or water may contain minerals that can corrode electronic circuits. In case the device is wet, please dry it completely.
- Do not use or store in dusty or dirty areas. This way can damage its detachable parts and electronic components.
- Do not store in excessive heat place. High temperatures can shorten the life of electronic devices, destroy batteries, and deform or melt some plastic parts.
- Do not store in excessive cold place. Otherwise, when the temperature rises to normal temperature, moisture will form inside which will destroy the board.
- Do not throw, knock or shake the device. Treating equipment roughly can destroy internal circuit boards and delicate structures.
- Do not wash with strong chemicals, detergents or strong detergents.
- Do not paint the device. Smudges can make debris block detachable parts up and affect normal operation.
- Do not throw the battery into the fire to prevent the battery from exploding. Damaged batteries may also explode.

All the above suggestions apply equally to your device, batteries and accessories.

If any device is not operating properly, please take it to the nearest authorized service facility for repairing.