

Wireless PH Sensor

Wireless Sensor Network Based on LoRa Technology



Copyright©Netvox Technology Co., Ltd.

This document contains proprietary technical information which is the property of NETVOX Technology and is issued in strict confidential and shall not be disclosed to others parties in whole or in parts without written permission of NETVOX Technology.

The specifications are subjected to change without prior notice.

Introduction

R718PA8 is a wireless communication device for pH value of acid, alkali, and salt solution. R718PA8 can detect the pH value and temperature of the solution. The body and the pH sensor are connected through the RS485 interface, and the detected data is transmitted to other devices through the wireless network for display. It adopts the wireless communication method that conforms to the LoRa™ protocol standard.

Operating Principle

The module R100H (R100L) communicates with the PH sensor via RS485.

Main Characteristic

- Adopt SX1276 wireless communication module
- DC 12V adapter power supply
- Protection level IP65/IP67 (optional)
- The base is attached with a magnet that can be attached to a ferromagnetic material object
- RS485 communication
- Compatible with LoRaWAN™ Class A
- Frequency hopping spread spectrum technology
- Configuring parameters and reading data via the third-party software platforms, and set alarms via SMS text and email (optional)
- Applicable to the third-party platforms: Actility/ ThingPark/ TTN/ MyDevices/ Cayenn

Application

- PH value detection

Dimension

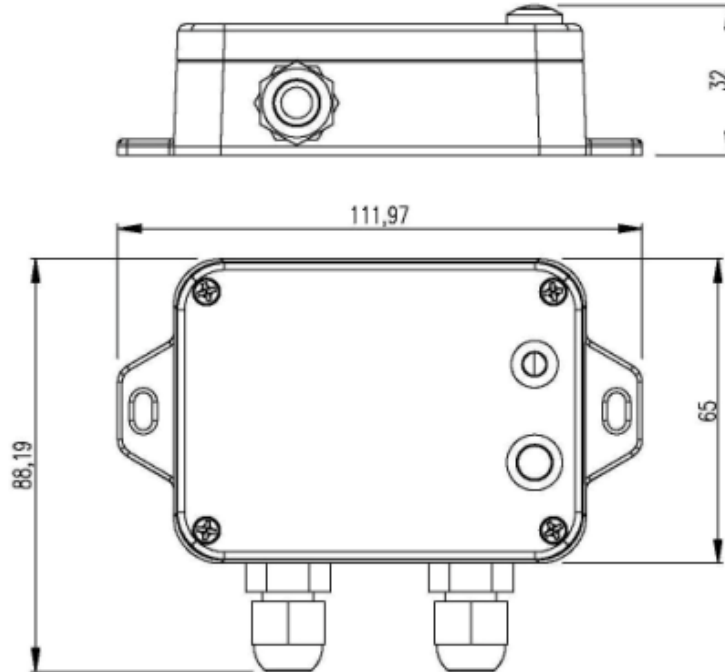

Electric

Power Supply	DC 12V adapter power supply
Operating Current	<70mA (external sensor)

*Specific electric characteristics will vary depending on the power supply voltage

PH Sensor Parameter

Power Supply	12V ~ 24VDC
Operating Water Temperature Range	0-65°C
PH Sensor Measurement Range	0-14PH
Resolution	0.01PH
Accuracy	±0.3PH
Usable Pressure Range	<0.2MPa
Temperature Compensation	Automatic Temperature Compensation (NTC)
Calibration Method	Two-point Calibration

Wireless PH Sensor

Cable Length	5m (Other lengths can be customized)
Liquid Container Material	PPR
Communication Port	RS485
Installation	Immersion mounting, 3/4 NPT thread
Power Consumption	0.2W@12V
IP Grade	IP68

Frequency

Frequency Range	863MHz-928MHz 470MHz-510MHz
TX Power	US915 20dbm; AS923 16dbm; AU915 20dbm; CN470 19.15dbm; EU868 16dbm; KR920 14dbm; IN865 20dbm;
Receive Sensitivity	-136 dBm (LoRa, Spreading Factor=12, Bit Rate=293bps) -121 dBm (FSK, Frequency deviation=5kHz, Bit Rate=1.2kbps)
Antenna Type	Built-in antenna
Communication Distance	10km (visible linear obstacle-free transmission distance, actual transmission distance depending on the environment)
Data Transfer Rate	0.3kbps~50kbps
Modulation Method	LoRa/FSK (Note: choose one of them)
Supportable LoRaWAN Band	EU863-870, US902-928, AU915-928, KR920-923, AS923, CN470-510 (Note: The frequency band is optional and needs to be configured before shipment)

Wireless PH Sensor

Physical

Dimension	L 112mm* W 88.19mm* H 32mm
Ambient Temperature Range	-20°C ~ 55°C
Host Body Weight	About 160g
Ambient Humidity Range	<90%RH (No condensation)
Storage Temperature Range	-40°C ~ 85°C