

**Wireless SO<sub>2</sub> Sensor**

---

**Wireless SO<sub>2</sub> Sensor  
R718PA6  
User Manual**

**Copyright©Netvox Technology Co., Ltd.**

This document contains proprietary technical information which is the property of NETVOX Technology. It shall be maintained in strict confidence and shall not be disclosed to other parties, in whole or in part, without written permission of NETVOX Technology. The specifications are subject to change without prior notice.

# Table of Content

1. Introduction.....	2
2. Appearance.....	3
3. Main Feature .....	3
4. Set Up Instruction .....	4
5. Data Report.....	5
6. Installation .....	7
7. Important Maintenance Instruction .....	8

# 1. Introduction

R718PA6 is a Class A device based on the LoRaWAN™ protocol of Netvox and is compatible with the LoRaWAN protocol.

R718PA6 can be connected with the sulfur dioxide sensor (RS485) to report the concentration of sulfur dioxide collected by the device to the corresponding gateway.

## **LoRa Wireless Technology:**

LoRa is a wireless communication technology dedicated to long distance and low power consumption. Compared with other communication methods, LoRa spread spectrum modulation method greatly increases to expand the communication distance. Widely used in long-distance, low-data wireless communications. For example, automatic meter reading, building automation equipment, wireless security systems, industrial monitoring. Main features include small size, low power consumption, transmission distance, anti-interference ability and so on.

## **LoRaWAN:**

LoRaWAN uses LoRa technology to define end-to-end standard specifications to ensure interoperability between devices and gateways from different manufacturers.

## 2. Appearance



## 3. Main Feature

- Adopt SX1276 wireless communication module
- 12V DC power supply
- SO<sub>2</sub> detection
- The base is attached with a magnet that can be attached to a ferrous object
- Main body protection level IP65 / IP67
- Compatible with LoRaWAN™ Class A
- Frequency hopping spread spectrum
- Configuring parameters and reading data via third-party software platforms, and set alarms via SMS text and email (optional)
- Applicable to third-party platforms: Actility/ThingPark, TTN, MyDevices/Cayenne

## 4.Set Up Instruction

### On/Off

Power on	DC12V adapter
Turn on	DC12V power supply, the green indicator flashing once means turn on successfully.
Turn off (Restore to factory setting)	Press and hold the function key for 5 seconds and the green indicator flashes 20 times.
Power off	Remove DC12V adapter.
Note:	<ol style="list-style-type: none"> <li>1. The first 5 seconds after power on, the device will be in engineering test mode.</li> <li>2. On/off interval is suggested to be about 10 seconds to avoid the interference of capacitor inductance and other energy storage components.</li> </ol>

### Network Joining

Never joined the network	<p>Turn on the device to search the network to join.</p> <p>The green indicator stays on for 5 seconds: success</p> <p>The green indicator remains off: fail</p>
Had joined the network (Not restore to the factory setting)	<p>Turn on the device to search the previous network to join.</p> <p>The green indicator stays on for 5 seconds: success</p> <p>The green indicator remains off: fail</p>
Fail to join the network	Suggest to check the device verification information on the gateway or consult your platform server provider.

### Function Key

Press and hold for 5 seconds	<p>Restore to factory setting / Turn off</p> <p>The green indicator flashes 20 times: success</p> <p>The green indicator remains off: fail</p>
Press once	<p>The device is in the network: the green indicator flashes once and sends a report</p> <p>The device is not in the network: the green indicator remains off</p>

## 5. Data Report

The device will send a version package report immediately after power-on. Then, it will send a report data with the concentration of sulfur dioxide **after it is powered on for 20s.**

The device sends data according to the default configuration before any other configuring.

### Default setting:

MaxTime: Max Interval = 3min = 180s

MinTime: The MinTime configuration is not available.

\*But the software has restriction, MinTime must be configured a number greater than 0.

Note:

1. The cycle of the device sending the data report is according to the default.
2. R718PA6 reports the concentration of sulfur dioxide.

Please refer Netvox LoRaWAN Application Command document and Netvox Lora Command Resolver <http://www.netvox.com.cn:8888/cmddoc> to resolve uplink data.

### Example of ConfigureCmd

FPort: 0x07

Bytes	1	1	Var (Fix =9 Bytes)
	CmdID	DeviceType	NetvoxPayloadData

**CmdID**– 1 byte

**DeviceType**– 1 byte – Device Type of Device

**NetvoxPayloadData**– var bytes (Max=9bytes)

Description	Device	Cmd ID	Device Type	NetvoxPayLoadData		
ConfigReport Req	R718PA6	0x01	0x57	MinTime (2bytes Unit: s)	MaxTime (2bytes Unit: s)	Reserved (5Bytes, Fixed 0x00)
ConfigReport Rsp		0x81		Status (0x00_success)	Reserved (8Bytes, Fixed 0x00)	
ReadConfig ReportReq		0x02		Reserved (9Bytes, Fixed 0x00)		
ReadConfig ReportRsp		0x82		MinTime (2bytes Unit: s)	MaxTime (2bytes Unit: s)	Reserved (5Bytes, Fixed 0x00)

(1) Configure the report MaxTime = 1min (The MinTime configuration is useless, but it needs to be set greater than 0 because of the software limitation.)

Downlink: 0157000A003C0000000000

Device Return:

8157000000000000000000000000 (configuration is success)

8157010000000000000000000000 (configuration is failure)

(2) Read device configuration parameters

Downlink: 025700000000000000000000

Device Return:

8257000A003C00000000000000 (device current configuration parameter)

## 6.Installation

1. The device has a built-in magnet (as the figure below). It can be attached to the surface of an iron object conveniently and quickly when it is installed.

In order to make the device installation more secure, use screws (purchased) to fix the device to the wall or other surface (such as the installation diagram). The device is screwed by two screws in the middle (purchased by users).

Note: Do not install the device in a metal shielded box or in an environment with other electrical equipment around it to avoid affecting the wireless transmission of the device.

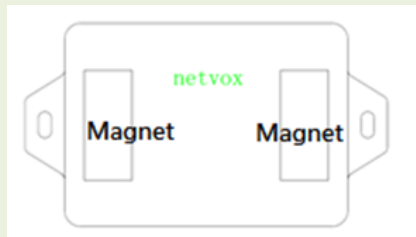

2. The device periodically reports the data according to Max Time. The default Max Time is 3min.

Note: Max Time can be modified by the downlink command, but it is not recommended to set this time too short.

3. The device can be used in scenarios such as:

- Chemical plant
- Environment protection detection
- Smoke/Gas emission monitor

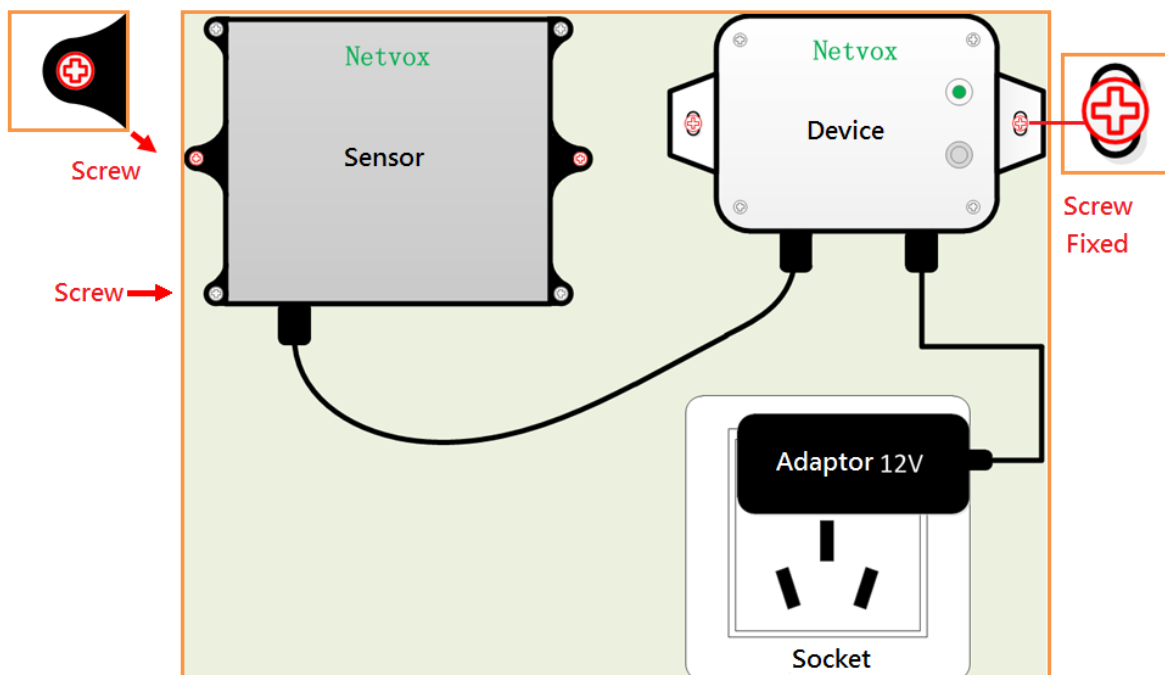



## 7.Important Maintenance Instruction

Kindly pay attention to the following in order to achieve the best maintenance of the product:

- Keep the equipment dry. Rain, moisture and various liquids or water may contain minerals that can corrode electronic circuits. In case the device is wet, please dry it completely.
- Do not use or store in dusty or dirty areas. This way can damage its detachable parts and electronic components.
- Do not store in excessive heat place. High temperatures can shorten the life of electronic devices, destroy batteries, and deform or melt some plastic parts.
- Do not store in excessive cold place. Otherwise, when the temperature rises to normal temperature, moisture will form inside which will destroy the board.
- Do not throw, knock or shake the device. Treating equipment roughly can destroy internal circuit boards and delicate structures.
- Do not wash with strong chemicals, detergents or strong detergents.
- Do not paint the device. Smudges can make debris block detachable parts up and affect normal operation.
- Do not throw the battery into the fire to prevent the battery from exploding.  
Damaged batteries may also explode.

All the above suggestions apply equally to your device, batteries and accessories.

If any device is not operating properly.

Please take it to the nearest authorized service facility for repairing.