

Wireless H₂S Sensor

R718PA4 User Manual

Copyright©Netvox Technology Co., Ltd.

This document contains proprietary technical information which is the property of NETVOX Technology. It shall be maintained in strict confidence and shall not be disclosed to other parties, in whole or in part, without written permission of NETVOX Technology. The specifications are subject to change without prior notice.

Table of Contents

1. Introduction	2
2. Appearance	3
3. Features	3
4. Set up Instruction.....	4
5. Data Report	5
5.1 Example of ReportDataCmd.....	5
5.2 Example of ConfigureCmd	7
6. Installation.....	8
7. Important Maintenance Instruction.....	9

1. Introduction

R718PA4 is a Netvox Class A device based on LoRaWAN™ protocol and compatible with the LoRaWAN protocol. R718PA4 can be connected to a hydrogen sulfide sensor with RS485 to report the concentration of hydrogen sulfide collected by the device to the corresponding gateway.

LoRa Wireless Technology:

LoRa is a wireless communication technology dedicated to long distance and low power consumption. Compared with other communication methods, LoRa spread spectrum modulation method greatly increases to expand the communication distance. Widely used in long-distance, low-data wireless communications. For example, automatic meter reading, building automation equipment, wireless security systems, industrial monitoring. Main features include small size, low power consumption, transmission distance, anti-interference ability and so on.

LoRaWAN:

LoRaWAN uses LoRa technology to define end-to-end standard specifications to ensure interoperability between devices and gateways from different manufacturers.

2. Appearance

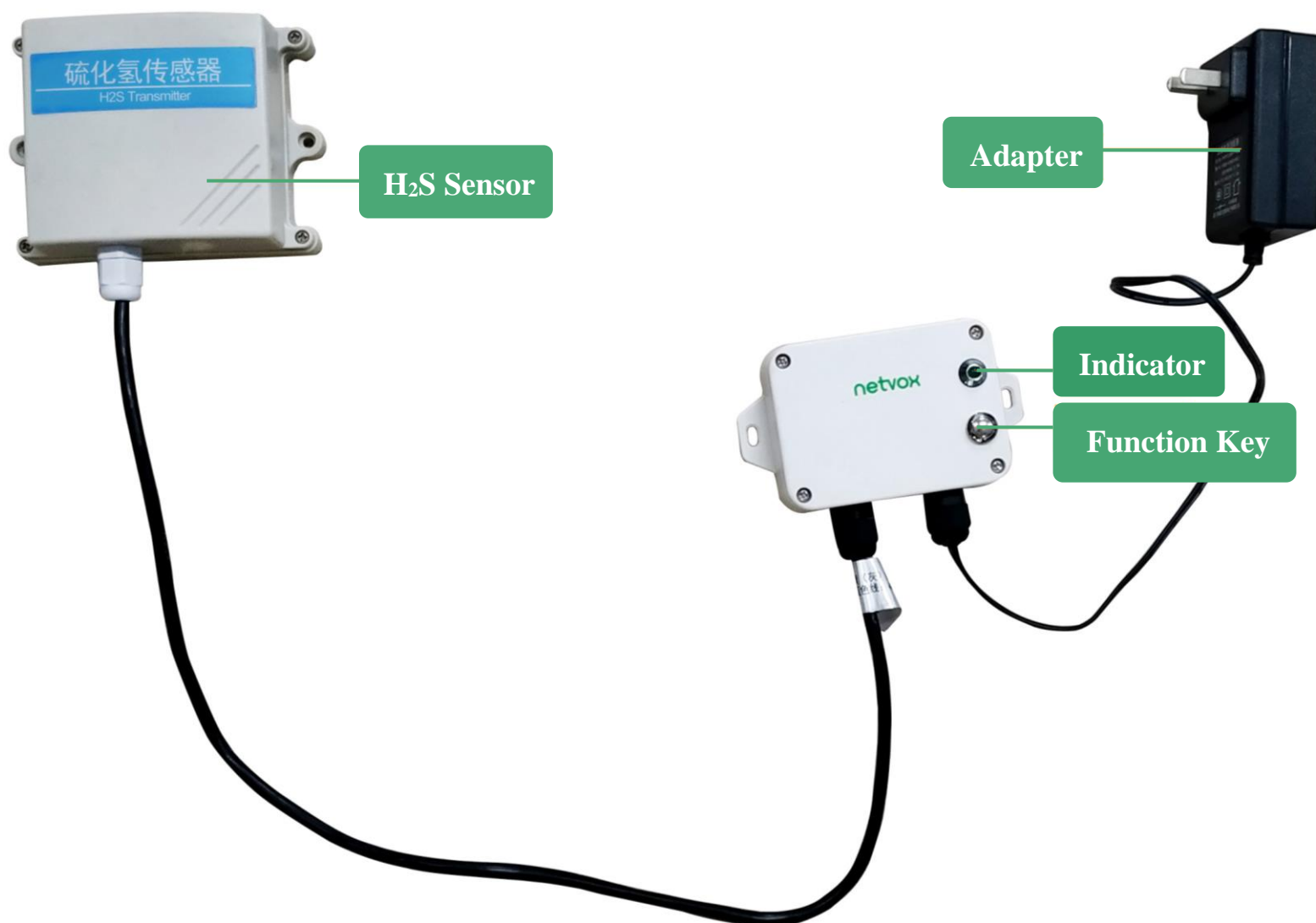

3. Features

- SX1276 wireless communication module
- 12V DC power supply
- H₂S detection
- Magnetic base
- Main body protection class IP65 / IP67 (optional)
- Compatible with LoRaWAN™ Class A
- Frequency hopping spread spectrum
- Configuration parameters can be configured via a third-party software platform, data can be read and alerts can be set via SMS text and email (optional)
- Applicable to third-party platforms: Actility/ThingPark, TTN, MyDevices/Cayenne

4. Set up Instruction

On/Off

Power on	DC12V adapter
Turn on	The green indicator flashes once.
Turn off (Reset to factory setting)	Press and hold the function key for 5 seconds and the green indicator flashes 20 times.
Power off	Remove DC12V adapter.
Note:	<ol style="list-style-type: none"> 5 seconds after power on, the device will be in engineering test mode. On/off interval is suggested to be about 10 seconds to avoid the interference of capacitor inductance and other energy storage components.

Network Joining

Never joined the network	<p><u>Turn on the device to search the network to join.</u></p> <p>The green indicator stays on for 5 seconds: Success</p> <p>The green indicator remains off: Fail</p>
Had joined the network	<p><u>Turn on the device to search the previous network to join.</u></p> <p>The green indicator stays on for 5 seconds: Success</p> <p>The green indicator remains off: Fail</p>
Fail to join the network (when the device is on)	Please check the device verification information on the gateway or consult your platform server provider.

Function Key

Press and hold for 5 seconds	<p><u>Restore to factory setting / Turn off</u></p> <p>The green indicator flashes 20 times: Success</p> <p>The green indicator remains off: Fail</p>
Press once	<p>The device is in the network: the green indicator flashes once and sends a report</p> <p>The device is not in the network: the green indicator remains off</p>

5. Data Report

The device will send a version package report immediately after power-on. Then, it will send a report data with the concentration of hydrogen sulfide **after it is powered on for 20s.**

The device sends data according to the default configuration before any other configuring.

Default setting:

MaxTime: Max Interval = 3min = 180s

MinTime: The MinTime configuration is not available.

*But the software has restriction, MinTime must be configured a number greater than 0.

Note:

1. The cycle of the device sending the data report is according to the default.
2. R718PA4 reports the concentration of hydrogen sulfide.

Please refer Netvox LoRaWAN Application Command document and Netvox Lora Command Resolver

<http://cmddoc.netvoxcloud.com/cmddoc> to resolve uplink data.

5.1 Example of ReportDataCmd

Fport: 0x06

Bytes	1	1	1	Var (Fix=8 Bytes)
	Version	DeviceType	ReportType	NetvoxPayloadData

Version– 1 byte –0x01—the Version of NetvoxLoRaWAN Application Command Version

DeviceType– 1 byte – Device Type of Device

ReportType – 1 byte –the presentation of the NetvoxPayloadData, according to the devicetype

NetvoxPayloadData– Fixed bytes (Fixed =8bytes)

Tips

1. Battery Voltage:

If the battery is equal to 0x00, it means that the device is powered by a DC power supply.

2. Version Packet:

When Report Type=0x00 is the version packet, such as 0157000B04202108130000, the firmware version is 2021.08.13.

3. Data Packet:

When Report Type=0x01 is data packet.

Device	Device Type	Report Type	NetvoxPayloadData				
R718PA4	0x57	0x06	Battery (1Byte, unit:0.1V)	NO2 (2Byte ,0.1ppm)	SO2 (2Byte ,0.1ppm)	H ₂ S (2Byte ,0.1ppm)	Reserved (1Byte, fixed 0x00)

Example of Uplink: 01570600FFFFFFFFF010200

1st byte (01): Version

2nd byte(57): DeviceType— R718PA4

3rd byte (06): ReportType

4th byte(00): Battery— 12V DC power supply

5th – 6th byte (FFFF): NO2— N/A

7th – 8th byte (FFFF): SO2— N/A

9th–10th byte (0102): H₂S— 25.8ppm 0102 (HEX) = 258 (DEC), 258* 0.1ppm = 25.8ppm

11th (00): Reserved

5.2 Example of ConfigureCmd

Fport: 0x07

Bytes	1	1	Var (Fix=9 Bytes)
	CmdID	DeviceType	NetvoxPayLoadData

CmdID– 1 byte

DeviceType– 1 byte – Device Type of Device

NetvoxPayLoadData– var bytes (Max=9bytes)

Description	Device	Cmd ID	DeviceType	NetvoxPayLoadData		
ConfigReportReq	R718PA4	0x01	0x57	MinTime (2bytes Unit:s)	MaxTime (2bytes Unit:s)	Reserved (5Bytes,Fixed 0x00)
ConfigReportRsp		0x81		Status (0x00_success)	Reserved (8Bytes, Fixed 0x00)	
ReadConfigReport Req		0x02		Reserved (9Bytes, Fixed 0x00)		
ReadConfigReport Rsp		0x82		MinTime (2bytes Unit:s)	MaxTime (2bytes Unit:s)	Reserved (5Bytes,Fixed 0x00)

(1) Configure R718PA4 report parameters:

MaxTime = 60s (0x3C);

MinTime configuration is not available, but it needs to be set greater than 0 because of the software limitation.

Downlink: 0157000A003C0000000000 003C (Hex) = 60 (Dec)

Response:

815700000000000000000000 (configuration successful)

815701000000000000000000 (configuration failed)

(2) Read device configuration parameters

Downlink: 025700000000000000000000

Device Returns: 8257000A003C0000000000 (current configuration parameter)

6. Installation

This product comes with a waterproof function. When using it, users can attach the back side to the iron surface, or use screws to fix both ends to the wall.

Note: (1) The lifespan of an electrochemical gas sensor is 1 to 2 years. A Sensor that passed over the lifespan could have inaccurate data while detection. The sensor should be sent back to factory for configuration or replacement of the probe.

(2) User may need a screwdriver to open the battery cover.

1. The device has a built-in magnet (as the figure below).

It can be attached to the surface of an iron object conveniently and quickly when it is installed.

In order to make the device installation more secure, use screws (purchased) to fix the device to the wall or other surface (such as the installation diagram). The device is screwed by two screws in the middle (purchased by users).

Note: Do not install the device in a metal shielded box or in an environment with other electrical equipment around it to avoid affecting the wireless transmission of the device.



2. The device periodically reports the data according to Max Time. The default Max Time is 1 hour.

Note: Max Time can be modified by the downlink command, but it is not recommended to set this time too small to avoid excessive battery drain.

3. The device can be used in scenarios such as:

- Sewer
- Pig farm
- Chemical plant
- Wastewater treatment plant
- Exploration drilling channel

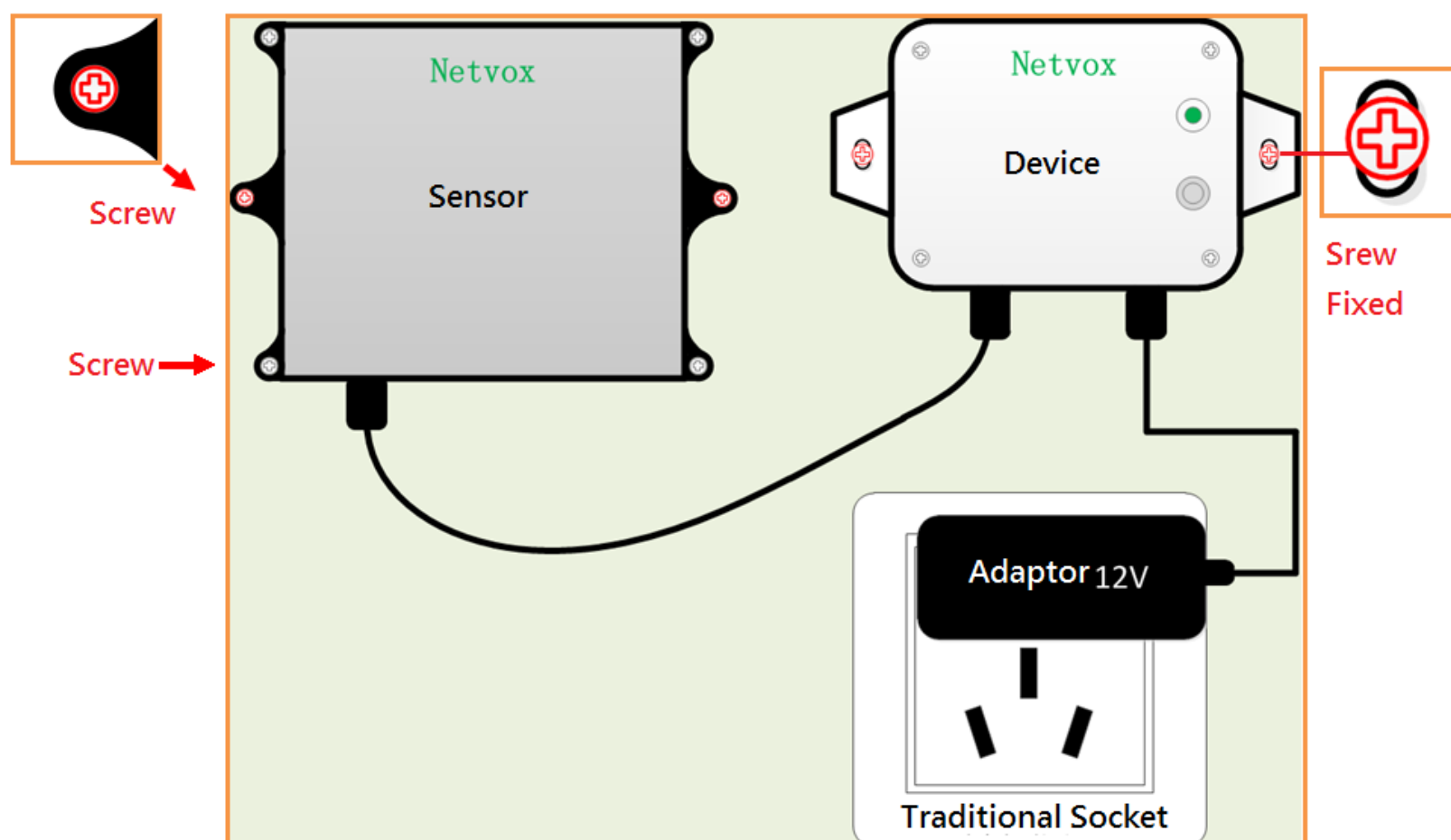

7. Important Maintenance Instruction

Kindly pay attention to the following in order to achieve the best maintenance of the product:

- Keep the device dry. Rain, moisture, or any liquid might contain minerals and thus corrode electronic circuits. If the device gets wet, please dry it completely.
- Do not use or store the device in dusty or dirty environment. It might damage its detachable parts and electronic components.
- Do not store the device under excessively hot condition. High temperature can shorten the life of electronic devices, destroy batteries, and deform or melt some plastic parts.
- Do not store the device in places that are too cold. Otherwise, when the temperature rises to normal temperature, moisture will form inside, which will destroy the board.
- Do not throw, knock or shake the device. Rough handling of device can destroy internal circuit boards and delicate structures.
- Do not clean the device with strong chemicals, detergents or strong detergents.
- Do not apply the device with paint. Smudges might block in the device and affect the operation.
- Do not throw the battery into the fire, or the battery will explode. Damaged batteries may also explode.

All of the above applies to your device, battery and accessories. If any device is not working properly, please take it to the nearest authorized service facility for repair