

# **Wireless 2-Input Dry Contact Interface**

## **R718J2 User Manual**

**Copyright© Netvox Technology Co., Ltd.**

This document contains proprietary technical information which is the property of NETVOX Technology. It shall be maintained in strict confidence and shall not be disclosed to other parties, in whole or in part, without written permission of NETVOX Technology. The specifications are subject to change without prior notice.

# Table of Contents

1. Introduction.....	2
2. Appearance.....	3
3. Features .....	3
4. Set up Instructions.....	4
5. Data Report .....	5
5.1 Example of ReportDataCmd.....	5
5.2 Example of ConfigureCmd.....	7
5.3 Example for MinTime/MaxTime logic .....	9
6. Installation.....	11
7. Information about Battery Passivation .....	12
7.1 To determine whether a battery requires activation .....	12
7.2 How to activate the battery .....	12
8. Important Maintenance Instruction .....	13
9. Precautions for Outdoor Installation.....	13

## 1. Introduction

R718J2 is a ClassA external 2-way dry contact device based on LoRaWAN open protocol of Netvox. It can externally connect various switches, buttons, relays and reed switch output. It can detect the closing or disconnecting signal of dry contact and is compatible with LoRaWAN protocol.

### **LoRa wireless technology**

LoRa is a wireless communication technology dedicated to long-distance low-power consumption. Its spread-spectrum modulation method greatly increases the communication distance compared with other communication methods, and can be widely used in long-distance low-rate IoT wireless communication fields in various occasions. Such as automatic meter reading, building automation equipment, wireless security systems, industrial monitoring and control. It has the characteristics of small size, low power consumption, long transmission distance and strong anti-interference ability.

### **LoRaWAN**

LoRaWAN defines an end-to-end standard specification using LoRa technology to ensure interoperability between devices and gateways from different vendors.

## 2. Appearance



## 3. Features

- SX1276 wireless communication module
- 2 ER14505 lithium batteries (3.6V / section) parallel power supply
- Dry contact detection
- Magnetic base
- IP65
- Compatible with LoRaWAN™ Class A
- Frequency hopping spread spectrum
- Applicable to third-party platforms: Actility/ThingPark, TTN, MyDevices/Cayenne
- Low power consumption and long battery life

## 4. Set up Instructions

### On/Off

Power on	Insert batteries. (Users may need a screwdriver to open the battery cover.)
Turn on	Press and hold the function key for 3 seconds until the green indicator flashes once.
Turn off (Factory resetting)	Press and hold the function key for 5 seconds until the green indicator flashes 20 times.
Power off	Remove Batteries.
Note:	<ol style="list-style-type: none"> <li>1. Remove and insert the battery; the device is off by default.</li> <li>2. On/off interval should be about 10 seconds to avoid the interference of capacitor inductance and other energy storage components.</li> <li>3. 5 seconds after power on, the device will be in engineering test mode.</li> </ol>

### Network Joining

Never joined the network	<p><u>Turn on the device to search the network.</u></p> <p>The green indicator stays on for 5 seconds: Success</p> <p>The green indicator remains off: Fail</p>
Had joined the network	<p><u>Turn on the device to search the previous network.</u></p> <p>The green indicator stays on for 5 seconds: Success</p> <p>The green indicator remains off: Fail</p>
Fail to Join the Network	Please check the device verification information on the gateway or consult your platform server provider.

### Function Key

Press and hold for 5 seconds	<p><u>Restore to factory setting / Turn off</u></p> <p>The green indicator flashes for 20 times: Success</p> <p>The green indicator remains off: Fail</p>
Press once	<p>The device is <u>in the network</u>: the green indicator flashes once and sends a report</p> <p>The device is <u>not in the network</u>: the green indicator remains off</p>

### Sleeping Mode

The device is on and in the network	<p>Sleeping period: Min Interval.</p> <p>When the reportchange exceeds the setting value or the state changes: send a data report according to Min Interval.</p>
-------------------------------------	--

### Low Voltage Warning

Low Voltage	3.2V
-------------	------

## 5. Data Report

When the device is turned on, it will immediately send a version package.

Data will be reported once per hour by default setting.

### Default Setting:

Maximum Time: 0x0E10 (3600s)

Minimum Time: 0x0E10 (3600s) // Detect the current voltage value every 3600s by default setting

Battery Change: 0x01 (0.1V)

LastMessageResendTime: 0x00

### Dry Contact Detection Trigger:

When the dry contact is connected, the data status bit is “1”.

When the dry contact is disconnected, the data status bit is “0”.

### Last Message Resend Time Function:

Resendtime = 0x00 or 0xFF, send the current dry contact state

Resendtime = 0x03 to 0xFE, send the current dry contact state, and resend the dry contact state after 3-254s

\*The function of Resendtime is supported by the firmware version after 2020/05/08 version.

Note: a. The device reports data depending on the burning configuration.

b. The interval between two reports must be the minimum interval.

c. Please check the Netvox LoRaWAN Application Command document and Netvox Lora Command Resolver

<http://cmddoc.netvoxcloud.com/cmddoc> to resolve uplink data.

Data report configuration and sending period are as follows:

Min. Interval (Unit: second)	Max. Interval (Unit: second)	Reportable Change	Current Change $\geq$ Reportable Change	Current Change $<$ Reportable Change
Any number between 1-65535	Any number between 1-65535	Cannot be 0	Report per Min. Interval	Report per Max. Interval

### 5.1 Example of ReportDataCmd

FPort: 0x06

Bytes	1	1	1	Var (Fix = 8 Bytes)
	Version	DeviceType	ReportType	NetvoxPayloadData

**Version**– 1 byte –0x01—the Version of NetvoxLoRaWAN Application Command Version

**DeviceType**– 1 byte – Device Type of Device

The devicetype is listed in Netvox LoRaWAN Application Devicetype doc

**ReportType** – 1 byte –the presentation of the NetvoxPayloadData, according the devicetype

**NetvoxPayloadData**– Fixed bytes (Fixed = 8 bytes)

## Tips

### 1. Battery Voltage:

The voltage value is bit 0 ~ bit 6, bit 7=0 is normal voltage, and bit 7=1 is low voltage.

Battery=0xA0, binary=1010 0000, if bit 7= 1, it means low voltage.

The actual voltage is 0010 0000 = 0x20 = 32, 32\* 0.1v = 3.2v

### 2. Version Packet:

When Report Type=0x00 is the version packet, such as 0143000A02202208220000, the firmware version is 2022.08.22.

### 3. Data Packet:

When Report Type=0x01 is data packet.

Device	Device Type	Report Type	NetvoxPayLoadData				
R718J2	0x43	0x00	SoftwareVersion (1 byte) Eg.0x0A—V1.0	HardwareVersion (1 byte)	DateCode (4 bytes, e.g. 0x20170503)		Reserved (2 bytes, fixed 0x00)
		0x01	Battery (1 byte, unit: 0.1V)	Status (1 byte, 0: off 1: on)	Status 2 (1 byte, 0: off 1: on)	Reserved (5 bytes, fixed 0x00)	

### Example of Uplink: 0143019F0000000000000000

1<sup>st</sup> byte (01): Version

2<sup>nd</sup> byte (43): DeviceType 0x43 — R718J2

3<sup>rd</sup> byte (01): ReportType

4<sup>th</sup> byte (9F): Battery—3.1V , 9F (HEX) = 31 (DEC), 31\* 0.1V = 3.1V

5<sup>th</sup> byte (00): Status—off

6<sup>th</sup> byte (00): Status—off

7<sup>th</sup> – 11<sup>th</sup> byte (0000000000): Reserved

## 5.2 Example of ConfigureCmd

FPort: 0x07

Bytes	1	1	Var (Fix = 9 Bytes)
	CmdID	DeviceType	NetvoxPayloadData

**CmdID**– 1 byte

**DeviceType**– 1 byte – Device Type of Device

**NetvoxPayloadData**– var bytes (Max = 9 bytes)

Description	Device	Cmd ID	Device Type	NetvoxPayloadData			
ConfigReport Req	R718J2	0x01	0x43	MinTime (2 bytes, Unit: s)	MaxTime (2 bytes, Unit: s)	BatteryChange (1 byte, Unit: 0.1v)	Reserved (4 bytes, Fixed 0x00)
ConfigReport Rsp		0x81		Status (0x00_success)	Reserved (8 bytes, Fixed 0x00)		
ReadConfigReportReq		0x02		Reserved (9 Bytes, Fixed 0x00)			
ReadConfigReportRsp		0x82		MinTime (2 bytes, Unit: s)	MaxTime (2 bytes, Unit: s)	BatteryChange (1 byte, Unit:0.1v)	Reserved (4 bytes, Fixed 0x00)

(1) Configure R718J2 device parameter

MinTime = 1min, MaxTime = 1min, BatteryChange = 0.1v

Downlink: 0143003C003C0100000000

Response: 814300000000000000000000 (configuration success)

814301000000000000000000 (configuration failure)

(2) Read R718J2 device parameter

Downlink: 024300000000000000000000

Response: 8243003C003C0100000000 (device current parameter)



Description	Device	CmdID	Device Type	NetvoxPayloadData	
SetLastMessage ResendtimeReq	All (0xFF) only used in contact switch device type	0x1F	0xFF	Resendtime (1 byte) Unit: 1s, Range: 3-254s when 0 or 255 no resend, default is no resend	Reserved (8 bytes, Fixed 0x00)
SetLastMessage ResendtimeRsp		0x9F		Status (0x00_success)	Reserved (8 bytes, Fixed 0x00)
GetLastMessage ResendtimeReq		0x1E		Reserved (9 Bytes, Fixed 0x00)	
GetLastMessage ResendtimeRsp		0x9E		Resendtime (1 byte) Unit: 1s, Range: 3-254s when 0 or 255 no resend, default is no resend	Reserved (8 bytes, Fixed 0x00)

Set resend time = 5 seconds

Downlink: 1FFF05000000000000000000

Response: 9FFF00000000000000000000 ( Configuration success )

9FFF01000000000000000000 ( Configuration failure )

Note: The function of Resendtime is supported by the firmware version after 2020.05.08.

### 5.3 Example for MinTime/MaxTime logic

**Example#1** based on MinTime = 1 Hour, MaxTime= 1 Hour, Reportable Change i.e. BatteryVoltageChange=0.1V

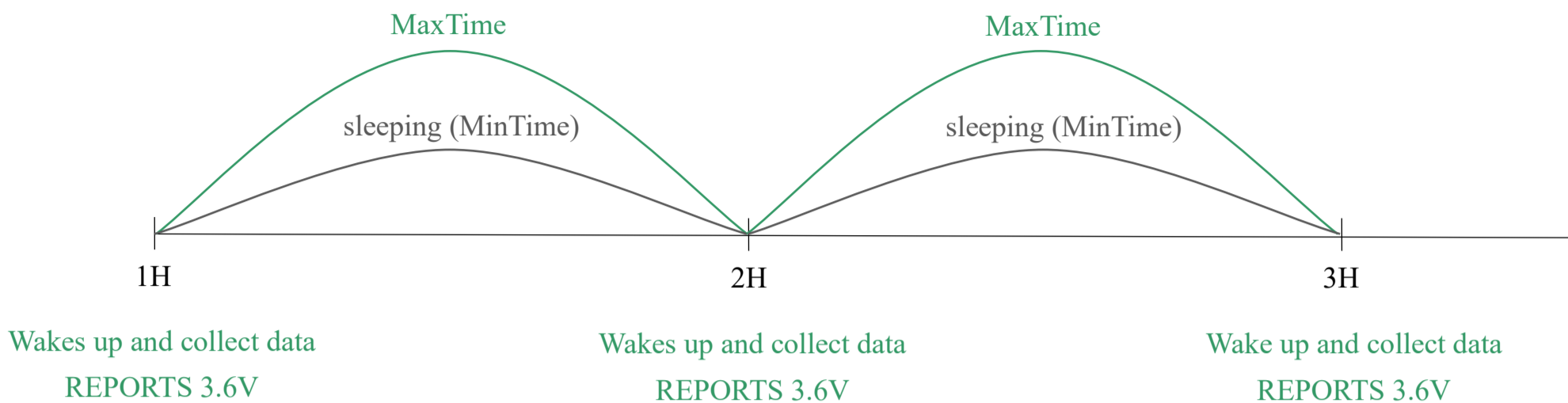

Note: MaxTime=MinTime. Data will only be report according to MaxTime (MinTime) duration regardless BatteryVoltageChange value.

**Example#2** based on MinTime = 15 Minutes, MaxTime= 1 Hour, Reportable Change i.e. BatteryVoltageChange= 0.1V.

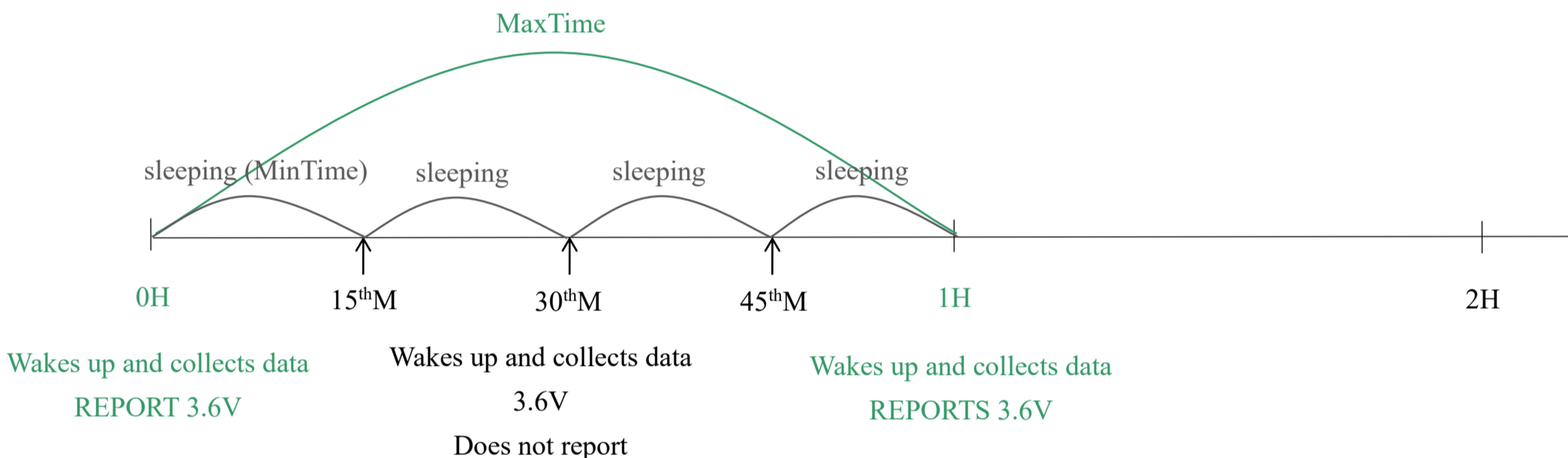

**Example#3** based on MinTime = 15 Minutes, MaxTime= 1 Hour, Reportable Change i.e. BatteryVoltageChange= 0.1V.

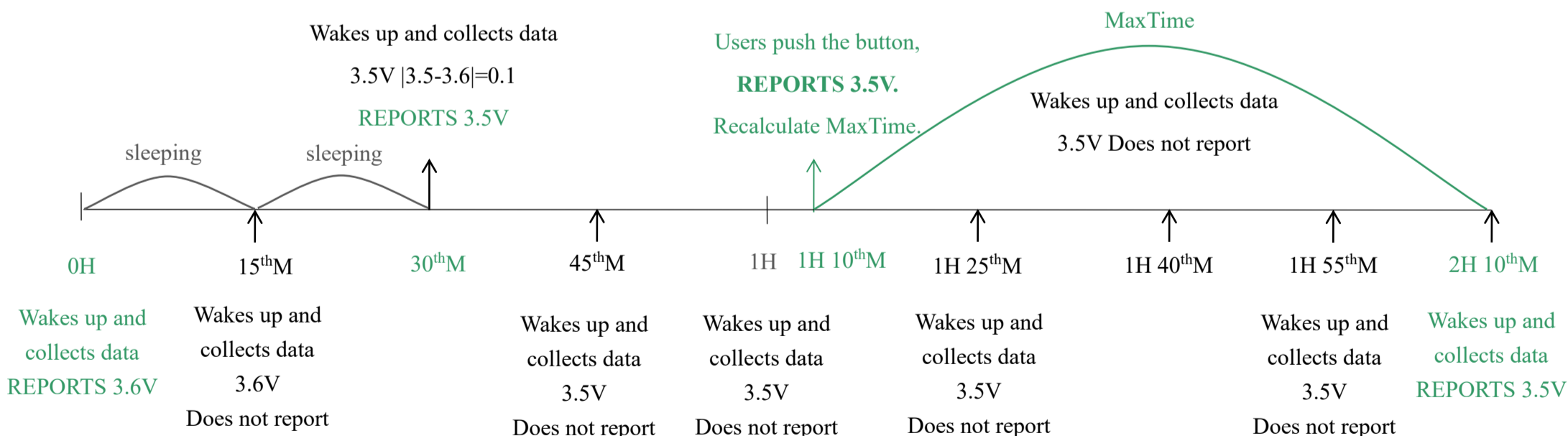

Notes:

- 1) The device only wakes up and performs data sampling according to MinTime Interval. When it is sleeping, it does not collect data.
- 2) The data collected is compared with the last data reported. If the data variation is greater than the ReportableChange value, the device reports according to MinTime interval. If the data variation is not greater than the last data reported, the device reports according to MaxTime interval.
- 3) We do not recommend to set the MinTime Interval value too low. If the MinTime Interval is too low, the device wakes up frequently and the battery will be drained soon.
- 4) Whenever the device sends a report, no matter resulting from data variation, button pushed or MaxTime interval, another cycle of MinTime/MaxTime calculation is started.

## 6. Installation

1. The R718J2 has a built-in magnet, which can be attached to the surface of an iron object during installation, which is convenient and quick. To make the installation firmer, please use screws (purchased separately) to fix the device to the wall or other surfaces.

Note: Do not install the device in a metal shielded box or in an environment surrounded by other electrical equipment to avoid affecting the wireless transmission of the device.

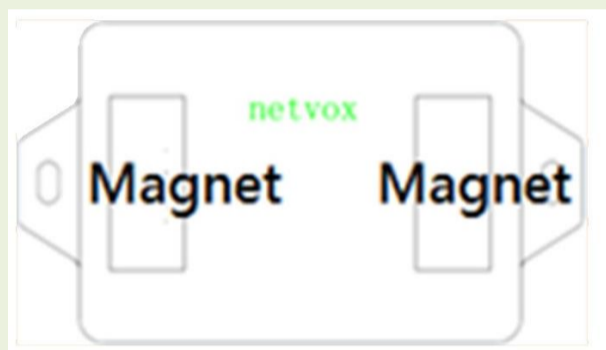

2. After the dry contact sensor detects the change of the dry contact state, it will report the data immediately.

3. If the battery voltage is detected that exceeds the change value during Min Time, the data will be reported immediately.

4. Whether the state of the dry contact is change, a piece of data will be reported regularly when the MaxTime comes.

Note:

⚠ (1) Dry contact can only receive signals from passive switch. Receiving voltage or current would damage the device.

(2) When the dry contact is connected, the data status bit is "1". When the dry contact is disconnected, the data status bit is "0".

Dry contact sensor (R718J2) can be used in the scenarios:

- Various switches and buttons
- Dry contact output of sensor
- The operating status of the equipment
- State monitoring of doors and windows in home or business

The occasion is necessary to judge the state of the sensor through the dry contact signal.

A diagram that the dry contact sensor (R718J2) connecting to two wired smoke sensors.

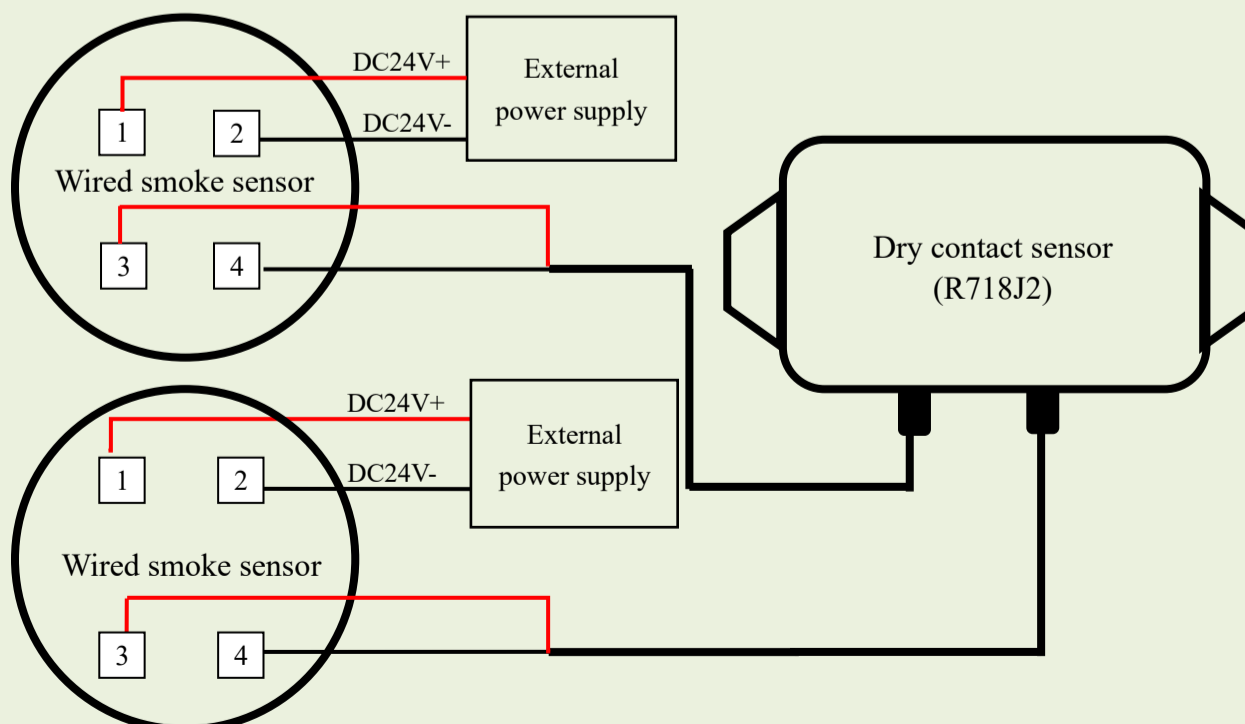

## 7. Information about Battery Passivation

Many of Netvox devices are powered by 3.6V ER14505 Li-SOCl<sub>2</sub> (lithium-thionyl chloride) batteries that offer many advantages including low self-discharge rate and high energy density. However, primary lithium batteries like Li-SOCl<sub>2</sub> batteries will form a passivation layer as a reaction between the lithium anode and thionyl chloride if they are in storage for a long time or if the storage temperature is too high. This lithium chloride layer prevents rapid self-discharge caused by continuous reaction between lithium and thionyl chloride, but battery passivation may also lead to voltage delay when the batteries are put into operation, and our devices may not work correctly in this situation.

As a result, please make sure to source batteries from reliable vendors, and it is suggested that if the storage period is more than one month from the date of battery production, all the batteries should be activated. If encountering the situation of battery passivation, users can activate the battery to eliminate the battery hysteresis.

### ER14505 Battery Passivation:

#### 7.1 To determine whether a battery requires activation

Connect a new ER14505 battery to a resistor in parallel, and check the voltage of the circuit.

If the voltage is below 3.3V, it means the battery requires activation.

#### 7.2 How to activate the battery

- a. Connect a battery to a resistor in parallel
- b. Keep the connection for 5~8 minutes
- c. The voltage of the circuit should be  $\geq 3.3$ , indicating successful activation.

Brand	Load Resistance	Activation Time	Activation Current
NHTONE	165 $\Omega$	5 minutes	20mA
RAMWAY	67 $\Omega$	8 minutes	50mA
EVE	67 $\Omega$	8 minutes	50mA
SAFT	67 $\Omega$	8 minutes	50mA

Note: If you buy batteries from other than the above four manufacturers, then the battery activation time, activation current, and required load resistance shall be mainly subject to the announcement of each manufacturer.

## 8. Important Maintenance Instruction

Kindly pay attention to the following to achieve the best maintenance of the product:

- Keep the device dry. Rain, moisture, or any liquid might contain minerals and thus corrode electronic circuits. If the device gets wet, please dry it completely.
- Do not use or store the device in a dusty or dirty environment. It might damage its detachable parts and electronic components.
- Do not store the device under extremely hot conditions. High temperatures can shorten the life of electronic devices, destroy batteries, and deform or melt some plastic parts.
- Do not store the device in places that are too cold. Otherwise, when the temperature rises, moisture that forms inside the device will damage the board.
- Do not throw, knock, or shake the device. Rough handling of equipment can destroy internal circuit boards and delicate structures.
- Do not clean the device with strong chemicals, detergents, or strong detergents.
- Do not apply the device with paint. Smudges might block the device and affect the operation.
- Do not throw the battery into the fire, or the battery will explode. Damaged batteries may also explode.

All of the above applies to your device, battery, and accessories. If any device is not operating properly, please take it to the nearest authorized service facility for repair.

## 9. Precautions for Outdoor Installation

According to the Enclosure Protection Class (IP code), the device is compliant to GB 4208-2008 standard, which is equivalent to IEC 60529:2001 degrees of protection provided by enclosures (IP Code).

IP Standard Test Method:

IP65: spray the device in all directions under 12.5L/min water flow for 3min, and the internal electronic function is normal.

IP65 is dustproof and able to prevent damage caused by water from nozzles in all directions from invading electrical appliances. It can be used in general indoor and sheltered outdoor environments. Installation in extreme weather conditions or direct exposure to sunlight and rain could damage the components of the device. Users may need to install the device under an awning (fig. 1) or face the side with an LED and function key downwards (fig. 2) to prevent malfunction.

IP67: the device is immersed in 1m deep water for 30 minutes, and the internal electronic function is normal.



Fig 1. Install under an awning



Fig 2. Install with LED and function key faced downwards