

# **Wireless Multi-Sensor Interface for 0-24V ADC, Dry Contact and 4-20mA Sensors**

## **R718IJK User Manual**

**Copyright©Netvox Technology Co., Ltd.**

This document contains proprietary technical information which is the property of NETVOX Technology. It shall be maintained in strict confidence and shall not be disclosed to other parties, in whole or in part, without written permission of NETVOX Technology. The specifications are subject to change without prior notice.

## Table of Contents

1. Introduction .....	2
2. Appearance .....	3
3. Features.....	3
4. Set Up Instructions .....	4
5. Data Report.....	5
5.1 Example of ReportDataCmd.....	5
5.2 Example of ConfigureCmd .....	7
5.3 GlobalCalibrateCmd .....	8
5.4 Set/GetSensorAlarmThresholdCmd .....	10
5.5 Example of NetvoxLoRaWANRejoin .....	11
5.6 Example for MinTime/MaxTime logic.....	12
6. Installation .....	14
7. Wiring .....	15
8. Information about Battery Passivation.....	17
8.1 To determine whether a battery requires activation.....	17
8.2 How to activate the battery .....	17
9. Important Maintenance Instruction .....	18
10. Precautions for Outdoor Installation .....	18

## 1. Introduction

R718IJK is a multi-interface detection device that is a Class A device based on the LoRaWAN open protocol and is compatible with the LoRaWAN protocol. The device is suitable for detecting 4mA to 20mA current, 0V to 24V voltage, and dry contact detection.

R718IJK is compatible with LoRaWAN protocol.

### LoRa Wireless Technology

LoRa is a wireless communication technology famous for its long-distance transmission and low power consumption. Compared with other communication methods, LoRa spread spectrum modulation technique greatly extend the communication distance. It can be widely used in any use case that requires long-distance and low-data wireless communications. For example, automatic meter reading, building automation equipment, wireless security systems, and industrial monitoring. It has features like small size, low power consumption, long transmission distance, strong anti-interference ability and so on.

### LoRaWAN

LoRaWAN uses LoRa technology to define end-to-end standard specifications to ensure interoperability between devices and gateways from different manufacturers.

## 2. Appearance

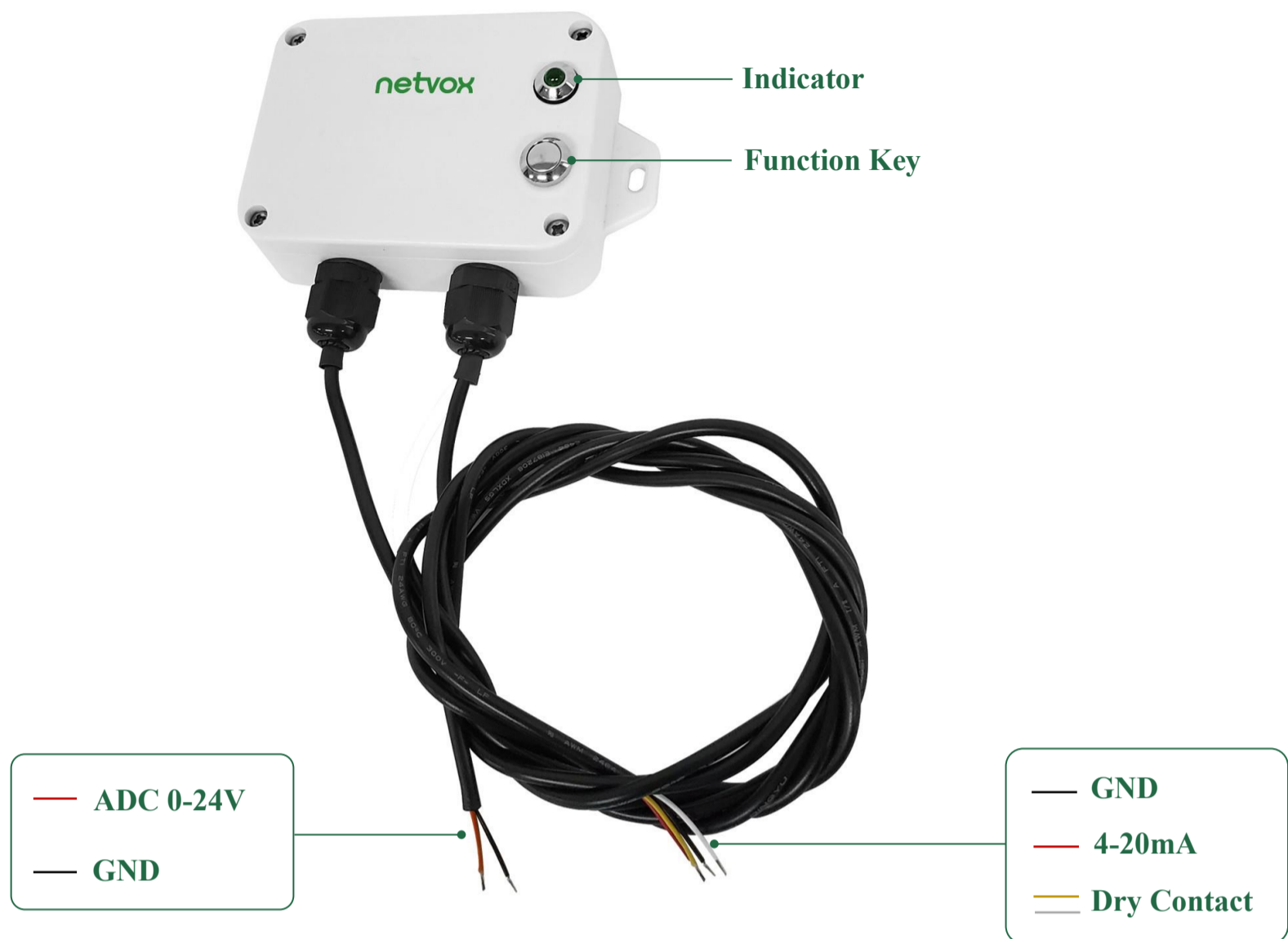

Note: a. The input of 4–20mA and 0–24V can only be direct current (DC).

b. The dry contact does not receive voltage or current.

## 3. Features

- SX1276 wireless communication module
- 2 sections of ER14505 battery in parallel (AA size 3.6V / section)
- 0 to 24V voltage detection
- 4 to 20mA current detection
- Dry contact detection
- Protection level IP65/ IP67 (optional)
- Compatible with LoRaWAN™ Class A
- Frequency hopping spread spectrum
- Applicable to third-party platforms: Actility/ThingPark, TTN, MyDevices/Cayenne
- Low power consumption and long battery life

Note: Please visit [http://www.netvox.com.tw/electric/electric\\_calc.html](http://www.netvox.com.tw/electric/electric_calc.html) for more information about battery lifespan.

## 4. Set Up Instructions

### On/Off

Power on	Insert batteries (User may need a screwdriver to open the battery cover.)
Turn on	Press and hold the function key for 3 seconds until the green indicator flashes once.
Turn off (Factory resetting)	Press and hold the function key for 5 seconds until the green indicator flashes 20 times.
Power off	Remove Batteries
Note	<ol style="list-style-type: none"> <li>1. Remove and insert the battery; the device is off by default.</li> <li>2. On/off interval should be about 10 seconds to avoid the interference of capacitor inductance and other energy storage components.</li> <li>3. 5 seconds after power on, the device is in engineering test mode.</li> </ol>

### Network Joining

Never join the network	<p><u>Turn on the device to search the network.</u></p> <p>The green indicator stays on for 5 seconds: Success</p> <p>The green indicator remains off: Fail</p>
Had joined the network (without factory resetting)	<p><u>Turn on the device to search the previous network.</u></p> <p>The green indicator stays on for 5 seconds: Success</p> <p>The green indicator remains off: Fail</p>
Fail to Join the Network	Please check the device verification information on the gateway or consult your platform server provider.

### Function Key

Press and hold for 5 seconds	<p><u>Factory Reset / Turn off</u></p> <p>The green indicator flashes 20 times: Success</p> <p>The green indicator remains off: Fail</p>
Press once	<p>The device is <u>in the network</u>: the green indicator flashes once and sends a report</p> <p>The device is <u>not in the network</u>: the green indicator remains off</p>

### Sleeping Mode

The device is on and in the network	<p>Sleeping period: Min Interval</p> <p>When the reportchange exceeds the setting value or the state changes, the device sends a data report according to Min Interval.</p>
--	---

### Low Voltage Warning

Low Voltage	3.2V
-------------	------

## 5. Data Report

The device will immediately send a version packet report and the data of attribute report.

The device sends data according to the default configuration before any other configuring.

### Default Setting:

MaxTime = 0x0384 (900s)

MinTime = 0x0384 (900s) // By default, the current voltage is detected every MinTime.

BatteryVoltageChange = 0x01 (0.1V)

ADC Raw Value Change = 0x0064 (100mV) // Configuration need to greater than 0x50 (80mV)

Current Change = 0x02 (2mA)

Note: a. The cycle of the device sending the data report is according to the default.

b. The interval between two reports must be the MinTime.

c. If there are special customized shipments, the setting will be changed according to customer's requirements.)

Please refer Netvox *LoRaWAN Application Command document* and *Netvox Lora Command Resolver*

<http://cmddoc.netvoxcloud.com/cmddoc> to resolve uplink data.

Data report configuration and sending period are as follows:

Min Interval (Unit: second)	Max Interval (Unit: second)	Reportable Change	Current Change $\geq$ Reportable Change	Current Change $<$ Reportable Change
Any number between 1-65535	Any number between 1-65535	Cannot be 0	Report per Min Interval	Report per Max Interval

### 5.1 Example of ReportDataCmd

**FPort: 0x06**

Bytes	1	1	1	Var (Fix = 8 Bytes)
	Version	DeviceType	ReportType	NetvoxPayloadData

**Version**– 1 byte –0x01—the Version of NetvoxLoRaWAN Application Command Version

**DeviceType**– 1 byte – Device Type of Device

The devicetype is listed in Netvox LoRaWAN Application Devicetype doc

**ReportType** – 1 byte –the presentation of the NetvoxPayloadData, according the devicetype

**NetvoxPayloadData**– Fixed bytes (Fixed = 8 bytes)

**Tips**

**1. Battery Voltage:**

The voltage value is bit 0 – bit 6, bit 7 = 0 is normal voltage, and bit 7 = 1 is low voltage.

Battery = 0xA0, binary = 1010 0000, if bit 7 = 1, it means low voltage.

The actual voltage is 0010 0000 = 0x20 = 32, 32\*0.1v = 3.2v

**2. Version Packet:**

When Report Type=0x00 is the version packet, such as 015C000A02202306050000, the firmware version is 2023.06.05.

**3. Data Packet:**

When Report Type=0x01 is data packet.

Device	Device Type	Report Type	NetvoxPayLoadData							
R718IJK	0x5C	0x00	SoftwareVersion (1 byte) e.g. 0x0A—V1.0		HardwareVersion (1 byte)		DateCode (4 bytes, e.g. 0x20170503)		Reserved (2 bytes, fixed 0x00)	
		0x01	Battery (1 byte, unit: 0.1V)	Status (1 byte, 0: off 1: on)	Current (1 byte, unit: 1mA)	ADCRawValue (2 bytes, unit: 1mv)	FineCurrent (1 byte, unit: 0.1mA)	ThresholdAlarm (1 byte, Bit0_LowAdcRaw1Al arm, Bit1_HighAdcRaw1Al arm, Bit2_LowFineCurrent Alarm, Bit3_HighFineCurrent Alarm, Bit4-7: Reserved)		Reserved (1 bytes, fixed 0x00)

**Example of Uplink: 015C019F00140B97C80000**

1<sup>st</sup> byte (01): Version

2<sup>nd</sup> byte (5C): DeviceType 0x5C—R718IJK

3<sup>rd</sup> byte (01): ReportType

4<sup>th</sup> byte (9F): Battery—3.1V (low voltage), 9F (HEX) = 31 (DEC), 31\* 0.1V = 3.1V

5<sup>th</sup> byte (00): Status—off

6<sup>th</sup> byte (14): Current—20mA, 14 (HEX) = 20 (DEC), 20\* 1mA = 20mA

7<sup>th</sup> 8<sup>th</sup> byte (0B97): ADCRawValue—2967mV, 0B97 (HEX) = 2967 (DEC), 2967\* 1mV = 2967mV

9<sup>th</sup> byte (C8): FineCurrent—20mA, C8 (HEX) = 200 (DEC), 200\* 0.1mA = 20.0mA

10<sup>th</sup> byte (00): ThresholdAlarm, 0x00 = 0000 0000 (Bin), Bit0, 1, 2, 3 = 0 (noalarm)

11<sup>th</sup> byte (00): Reserved

## 5.2 Example of ConfigureCmd

FPort: 0x07

Bytes	1	1	Var (Fix =9 Bytes)
	CmdID	DeviceType	NetvoxPayLoadData

**CmdID**– 1 byte

**DeviceType**– 1 byte – Device Type of Device

**NetvoxPayLoadData**– var bytes (Max = 9 bytes)

Description	Device	Cmd ID	Device Type	NetvoxPayLoadData					
ConfigReport Req	R718IJK	0x01	0x5C	MinTime (2 bytes, Unit: s)	MaxTime (2 bytes, Unit: s)	BatteryChange (1 byte, Unit: 0.1v)	ADCRawValueChange (2 bytes, Unit: 1mV)	CurrentChange (1 byte, Unit: 1mA)	Reserved (1 byte, Fixed 0x00)
ConfigReport Rsp		0x81		Status (0x00_success)			Reserved (8 bytes, Fixed 0x00)		
ReadConfigReportReq		0x02		Reserved (9Bytes, Fixed 0x00)					
ReadConfigReportRsp		0x82		MinTime (2 bytes, Unit: s)	MaxTime (2 bytes, Unit: s)	BatteryChange (1 byte, Unit: 0.1v)	ADCRawValueChange (2 bytes, Unit: 1mV)	CurrentChange (1 byte, Unit: 1mA)	Reserved (1 byte, Fixed 0x00)

(1) Configure R718IJK device parameter

MinTime = 1min, MaxTime = 1min, BatteryChange = 0.1v, ADCRawValue Change=100mV, Current Change =2mA

Downlink: 015C003C003C0100640200

Response: 815C0000000000000000 (configuration success)

815C010000000000000000 (configuration failure)

(2) Read R718IJK device parameter

Downlink: 025C0000000000000000

Response: 825C003C003C0100640200 (device current parameter)



### 5.3 GlobalCalibrateCmd

FPort: 0x0E

Description	Cmd ID	SensorType	PayLoad (Fix = 9 Bytes)					
SetGlobalCalibrateReq	0x01	0x31 ADC_Sensor	Channel (1byte) 0_Channel1 1_Channel2, etc.	Multiplier (2 bytes, Unsigned)	Divisor (2 bytes, Unsigned)	DeltValue (2 bytes, Signed)	Reserved (2 bytes, Fixed 0x00)	
SetGlobalCalibrateRsp	0x81		Channel (1 byte) 0_Channel1 1_Channel2, etc.	Status (1 byte,0x00_success)			Reserved (7 bytes, Fixed 0x00)	
GetGlobalCalibrateReq	0x02		0x32 Current_Sensor	Channel (1 byte) 0_Channel1 1_Channel2, etc.				Reserved (8 bytes, Fixed 0x00)
GetGlobalCalibrateRsp	0x82			Channel (1byte) 0_Channel1 1_Channel2, etc.	Multiplier (2 bytes, Unsigned)	Divisor (2 bytes, Unsigned)	DeltValue (2 bytes, Signed)	Reserved (2 bytes, Fixed 0x00)
ClearGlobalCalibrateReq	0x03	Reserved (10 bytes, Fixed 0x00)						
ClearGlobalCalibrateRsp	0x83	Status (1 byte, 0x00_success)			Reserved (9 bytes, Fixed 0x00)			

SensorType = 0x31, channel = 0x00;

SensorType = 0x32, channel = 0x01

Calibrate the sensor by increasing 100mV, the Multiplier =0x0001, Divisor = 0x0001, and DeltValue = 0x0064

(1) SetGlobalCalibrateReq

Downlink: 0131000001000100640000

Response: 8131000000000000000000

(2) GetGlobalCalibrateReq

Downlink: 0231000000000000000000

Response: 8231000001000100640000

Calibrate the sensor by decreasing 100mV, the Multiplier =0x0001, Divisor = 0x0001, and DeltValue = 0xFF9C

(1) SetGlobalCalibrateReq

Downlink: 01310000010001FF9C0000

Response: 8131000000000000000000

(2) GetGlobalCalibrateReq

Downlink: 0231000000000000000000

Response: 82310000010001FF9C0000

Clear calibration

ClearGlobalCalibrateReq

Downlink:03 0000 0000 0000 0000 0000

Response: 83 0000 0000 0000 0000 0000

## 5.4 Set/GetSensorAlarmThresholdCmd

Fport:0x10

CmdDescriptor	CmdID (1 byte)	Payload (10 bytes)			
SetSensorAlarm ThresholdReq	0x01	Channel (1 byte, 0x00_Channel1, 0x01_Chanel2, 0x02_Channel3, etc.)	SensorType (1byte, 0x00_Disable ALL SensorthresholdSet 0x0F_ADCRawValue, 0x10_FineCurrent,	SensorHighThreshold (4 bytes, Unit: 1mV/mA)	SensorLowThreshold (4 bytes, Unit: 1mV/mA)
SetSensorAlarm ThresholdRsp	0x81	Status (0x00_success)	Reserved (9Bytes,Fixed 0x00)		
GetSensorAlarm ThresholdReq	0x02	Channel (1 byte, 0x00_Channel1, 0x01_Chanel2, 0x02_Channel3, etc.)	SensorType (1 byte, 0x00_Disable ALL SensorthresholdSet 0x0F_ADCRawValue, 0x10_FineCurrent,	Reserved (8 bytes, Fixed 0x00)	
GetSensorAlarm ThresholdRsp	0x82	Channel (1 byte, 0x00_Channel1, 0x01_Chanel2, 0x02_Channel3, etc.)	SensorType (1 byte, 0x00_Disable ALL SensorthresholdSet 0x0F_ADCRawValue, 0x10_FineCurrent,	SensorHighThreshold (4 bytes, Unit: 1mV/mA)	SensorLowThreshold (4 bytes, Unit: 1mV/mA)

ADCRawValue = 0x00\_Channel1; FineCurrent = 0x01\_Channel;

ADCRawValue HighThreshold = 500mV (0x000001F4); LowThreshold = 100Mv (0x00000064)

When the ADCRawValue is higher or lower the threshold, the ThresholdAlarm bit = 1.

### (1) SetSensorAlarmThresholdReq

Downlink: 01000F000001F400000064

Response: 810000000000000000000000

### (3) Clear all thresholds (SensorType = 0x00)

Downlink: 010000000000000000000000

Response: 810000000000000000000000

### (2) GetSensorAlarmThresholdReq

Downlink: 02000F000000000000000000

Response: 82000F000001F400000064

Note: a. The last configuration would be kept as user reset the device back to the factory setting.

b. Set SensorHigh/LowThreshold as 0xFFFFFFFF to disable threshold.

## 5.5 Example of NetvoxLoRaWANRejoin

(NetvoxLoRaWANRejoin command is to check if the device is still in the network. If the device is disconnected, it will automatically rejoin back to the network.)

**Fport: 0x20**

CmdDescriptor	CmdID (1 byte)	Payload (5 bytes)	
SetNetvoxLoRaWANRejoinReq	0x01	RejoinCheckPeriod (4 bytes, Unit: 1s 0xFFFFFFFF Disable NetvoxLoRaWANRejoinFunction)	RejoinThreshold (1 byte)
SetNetvoxLoRaWANRejoinRsp	0x81	Status (1 byte, 0x00_success)	Reserved (4 bytes, Fixed 0x00)
GetNetvoxLoRaWANRejoinReq	0x02	Reserved (5 bytes, Fixed 0x00)	
GetNetvoxLoRaWANRejoinRsp	0x82	RejoinCheckPeriod (4 bytes, Unit:1s)	RejoinThreshold (1 byte)

### (1) Configure parameters

RejoinCheckPeriod = 60min (0x00000E10); RejoinThreshold = 3 times (0x03)

Downlink: 0100000E1003

Response: 810000000000 (configuration succeed)

810100000000 (configuration fail)

### (2) Read configuration

Downlink: 020000000000

Response: 8200000E1003

Note: a. Set RejoinCheckThreshold as 0xFFFFFFFF to stop the device from rejoining the network.

b. The last configuration would be kept when the device is factory reset.

c. Default setting: RejoinCheckPeriod = 2 (hr) and RejoinThreshold = 3 (times)



Note:

- 1) The device only wakes up and performs data sampling according to MinTime Interval. When it is sleeping, it does not collect data.
- 2) The data collected is compared with the last data reported. If the data variation is greater than the ReportableChange value, the device reports according to MinTime interval. If the data variation is not greater than the last data reported, the device reports according to MaxTime interval.
- 3) We do not recommend to set the MinTime Interval value too low. If the MinTime Interval is too low, the device wakes up frequently and the battery will be drained soon.
- 4) Whenever the device sends a report, no matter resulting from data variation, button pushed or MaxTime interval, another cycle of MinTime/MaxTime calculation is started.

## 6. Installation

1. R718IJK has the built-in magnet (as the figure below). When installed, it can be attached to the surface of an object with iron which is convenient and quick.

To make the installation more secure, use screws (purchased) to secure the unit to a wall or other surface (as the figure below).

Note:

Do not install the device in a metal shielded box or in an environment with other electrical equipment around it to avoid affecting the wireless transmission of the device.

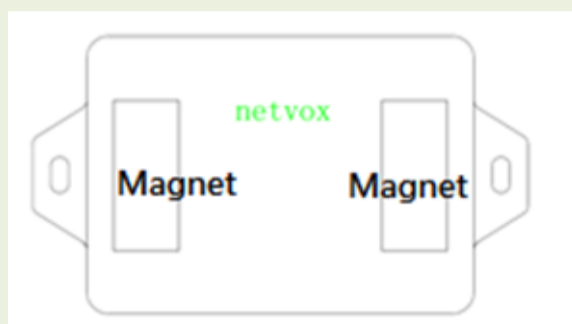

1. The ADC sampling line, dry contact sampling, and current sampling line of R718IJK are respectively connected according to the wiring method of Fig. 1, Fig. 2, Fig. 3 and Fig. 4.

2. R718IJK detects the battery voltage of the device, the voltage of the ADC sampling line, and the current of the current sampling line according to the MinTime, and compares the values with the last reported battery voltage value, ADC voltage value, and current value. When the default variation is exceeded (the default variation of battery voltage is 0.1V), the currently detected data is sent immediately. Otherwise, the device will report data regularly according to MaxTime. Data can also be reported by pressing the button.

3. Dry contact sampling line will report data immediately after detecting the change of dry contact status.

Note:

- When the dry contact is connecting, the data status bit is “1”.  
When the dry contact is disconnecting, the data status bit is “0”.
- The wiring method of current detection is divided into 2-wire wiring method and 3-wire wiring method as Fig. 3 and Fig. 4 shown below.

The **ADC detection** function of R718IJK is suitable for the following scenarios:

- Signal isolation and amplification in industrial field
- Linear actuator for solenoid valve and proportional valve
- Linear controller with magnetic switch
- Electromagnetically driven coil or high-power load
- Ground wire interference suppression

The signal isolation transmitter with output signal 0-24V.

The **dry contact** function of R718IJK can be used in the following scenarios:

- Various switches and buttons
- Dry contact output of sensor
- The operating status of the equipment
- Door and window condition monitoring for home or business

The occasion is necessary to judge the sensor state by dry contact signal.

The **current detection** function of R718IJK is suitable for the following scenarios:

- Pressure transmitter
- Differential pressure transmitter
- Level transmitter
- Flowmeter

Such as transmitters with output signal 4-20mA.

## 7. Wiring

**!** Improper installation would damage the main parts of R718IJK. Please follow the instructions while wiring.

- The input of 4–20mA and 0–24V can only be direct current (DC).
- Dry contact does not receive voltage or current.

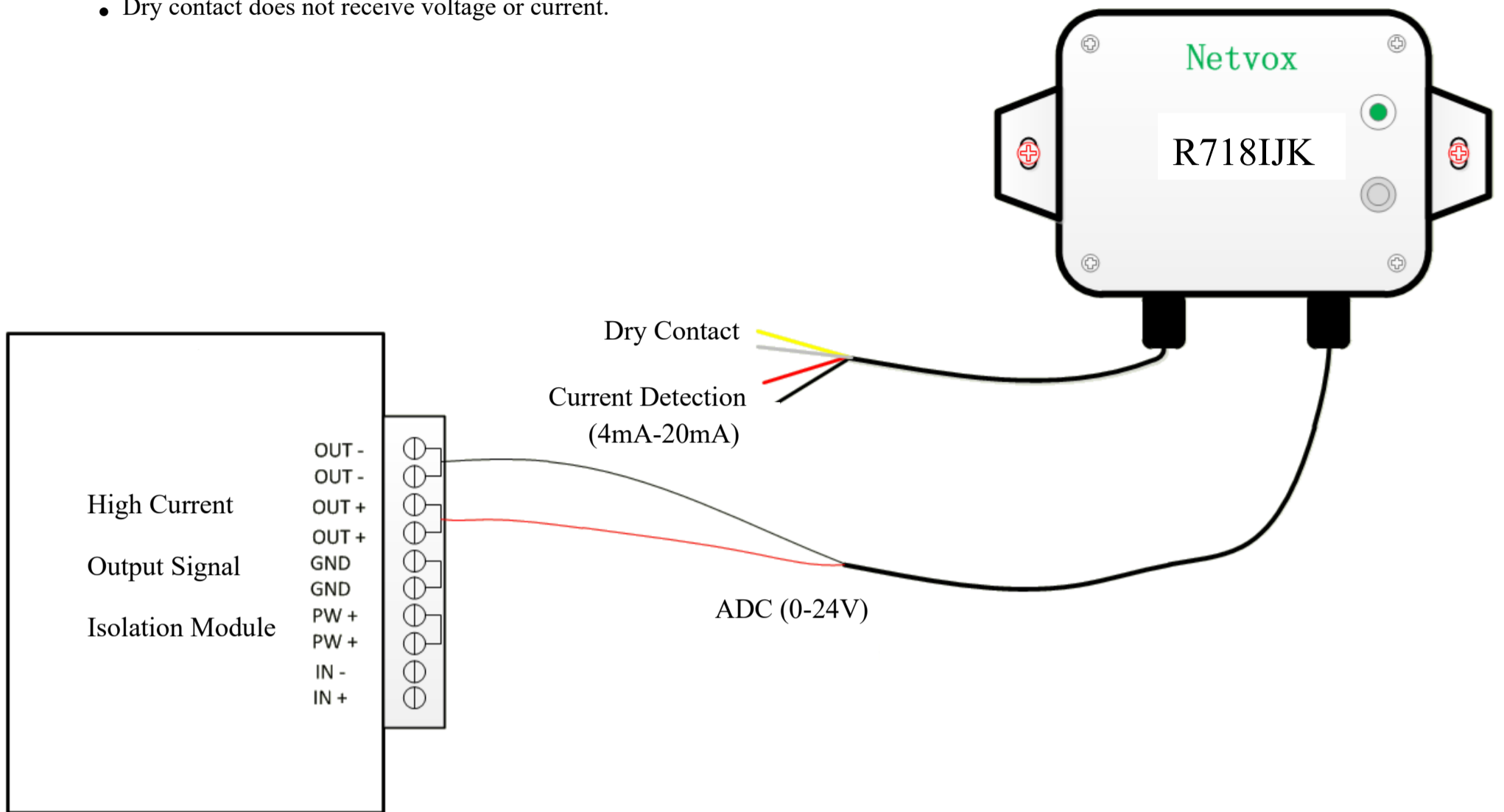

Fig. 1. ADC (0-24V) Detection Wiring Diagram

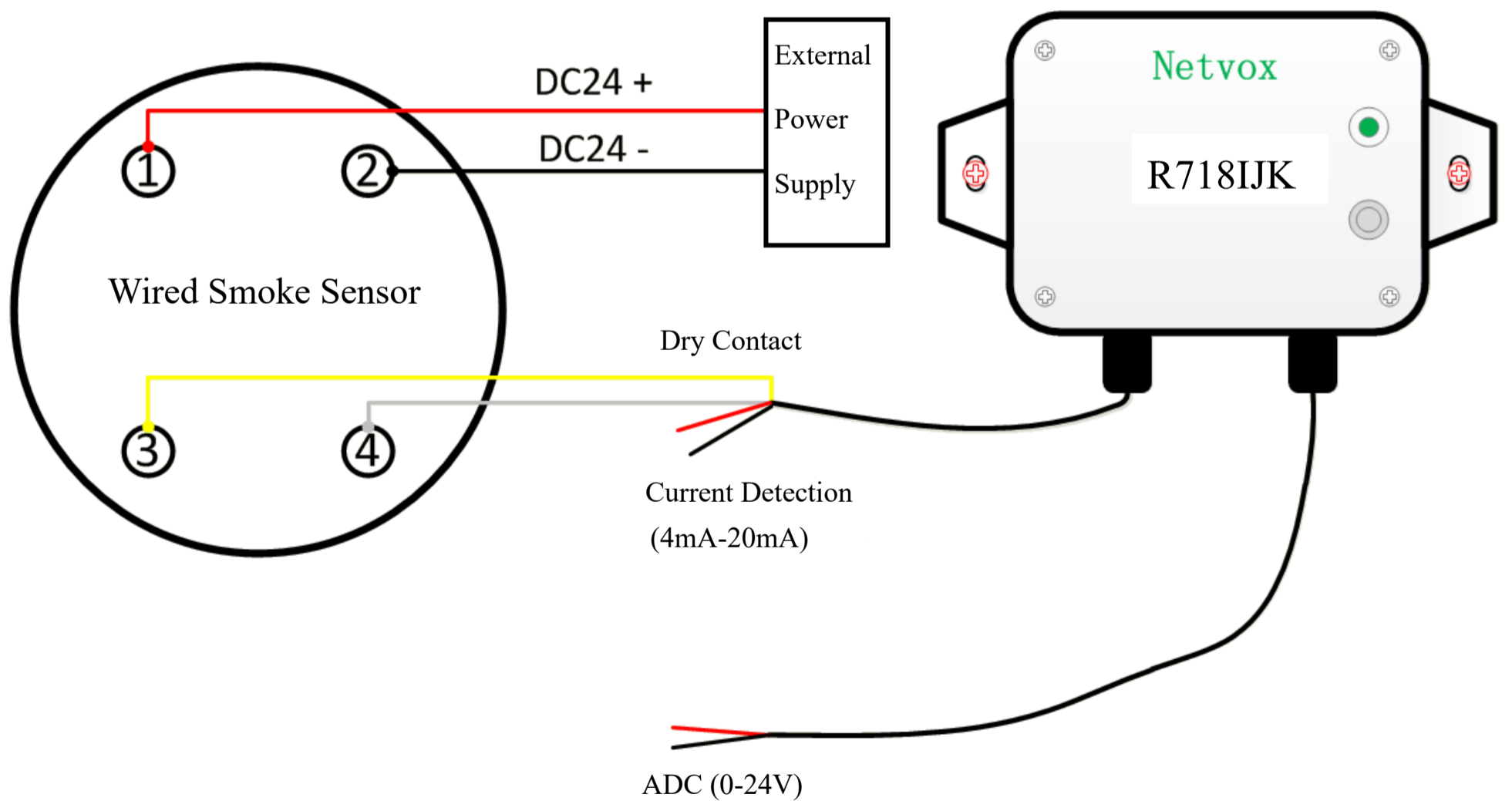

Fig. 2. Dry Contact Wiring Diagram



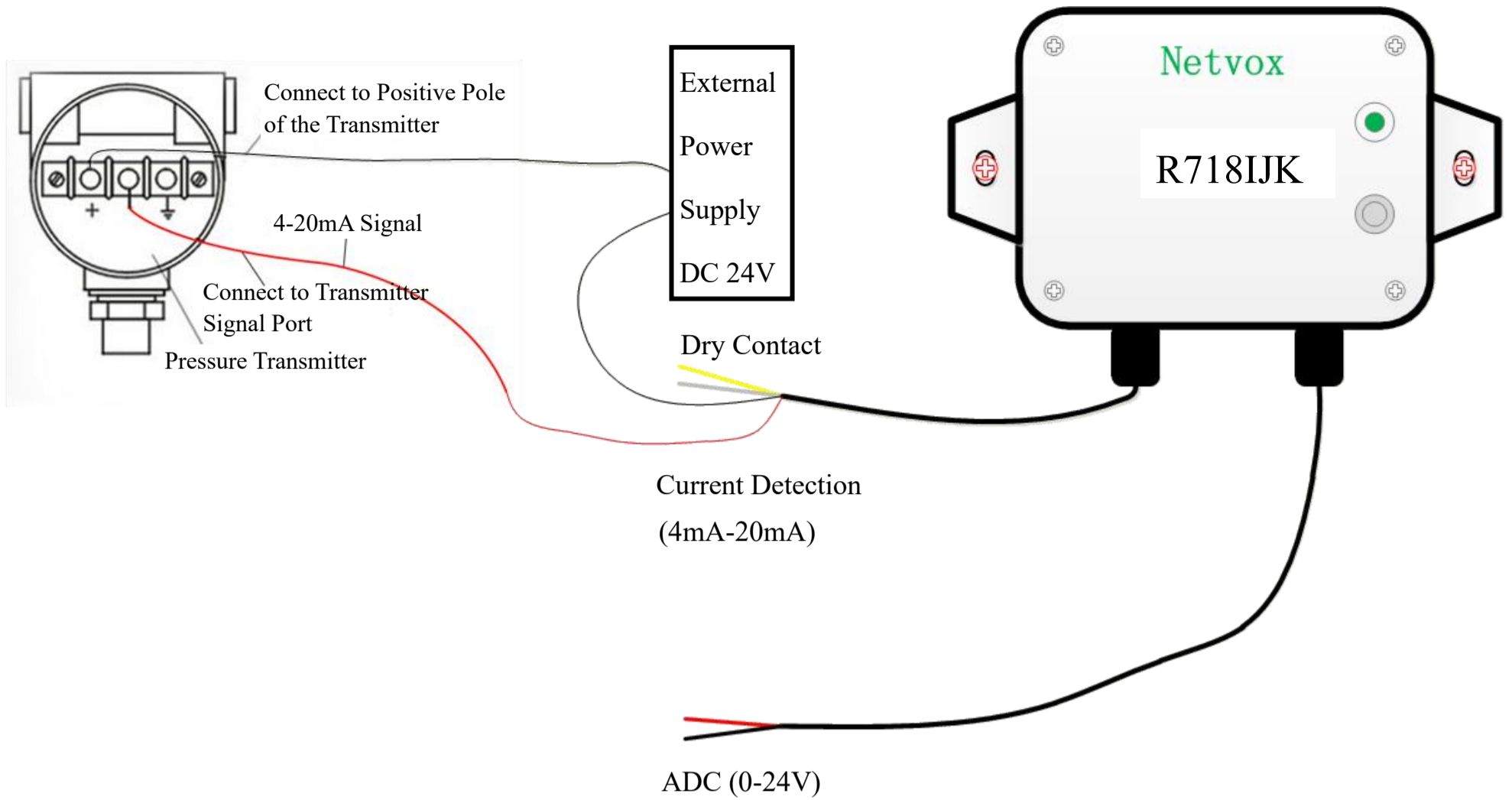

Fig. 3. Current Detection 2-Wire Wiring Diagram

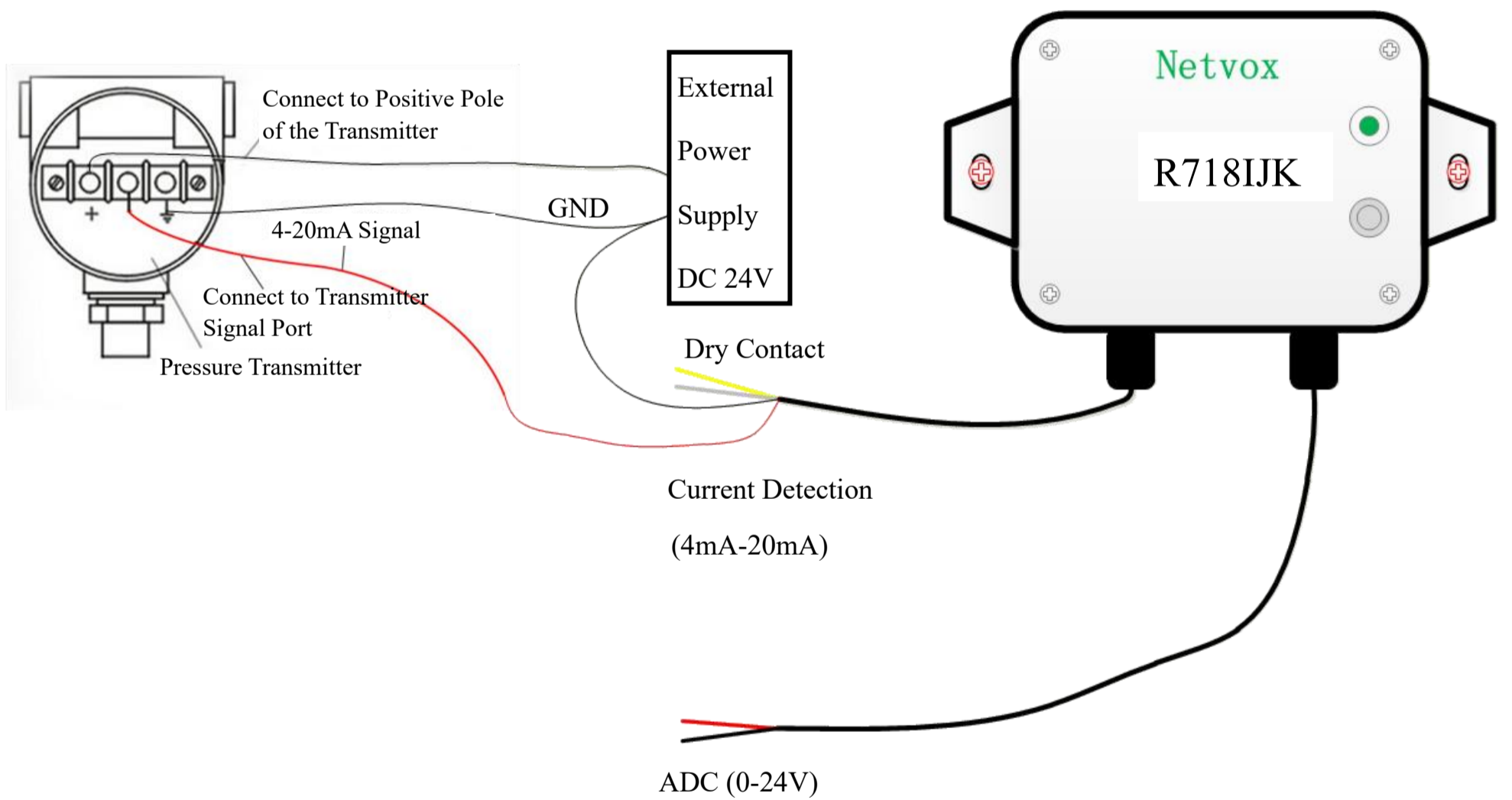

Fig. 4. Current Detection 3-Wire Wiring Diagram

Note:

- Please do not disassemble the device unless it is required to replace the batteries.
- Please do not touch the waterproof gasket, LED indicator light, function keys when replacing the batteries. Please use suitable screwdriver to tighten the screws (if using an electric screwdriver, it is recommended to set the torque as 4kgf) to ensure the device is impermeable.

## 8. Information about Battery Passivation

Many of Netvox devices are powered by 3.6V ER14505 Li-SOCl<sub>2</sub> (lithium-thionyl chloride) batteries that offer many advantages including low self-discharge rate and high energy density. However, primary lithium batteries like Li-SOCl<sub>2</sub> batteries will form a passivation layer as a reaction between the lithium anode and thionyl chloride if they are in storage for a long time or if the storage temperature is too high. This lithium chloride layer prevents rapid self-discharge caused by continuous reaction between lithium and thionyl chloride, but battery passivation may also lead to voltage delay when the batteries are put into operation, and our devices may not work correctly in this situation.

As a result, please make sure to source batteries from reliable vendors, and it is suggested that if the storage period is more than one month from the date of battery production, all the batteries should be activated. If encountering the situation of battery passivation, users can activate the battery to eliminate the battery hysteresis.

### ER14505 Battery Passivation:

#### 8.1 To determine whether a battery requires activation

Connect a new ER14505 battery to a resistor in parallel, and check the voltage of the circuit.

If the voltage is below 3.3V, it means the battery requires activation.

#### 8.2 How to activate the battery

- a. Connect a battery to a resistor in parallel
- b. Keep the connection for 5~8 minutes
- c. The voltage of the circuit should be  $\geq 3.3$ , indicating successful activation.

Brand	Load Resistance	Activation Time	Activation Current
NHTONE	165 $\Omega$	5 minutes	20mA
RAMWAY	67 $\Omega$	8 minutes	50mA
EVE	67 $\Omega$	8 minutes	50mA
SAFT	67 $\Omega$	8 minutes	50mA

Note:

If you buy batteries from other than the above four manufacturers, then the battery activation time, activation current, and required load resistance shall be mainly subject to the announcement of each manufacturer.

## 9. Important Maintenance Instruction

Kindly pay attention to the following to achieve the best maintenance of the product:

- Keep the device dry. Rain, moisture, or any liquid might contain minerals and thus corrode electronic circuits. If the device gets wet, please dry it completely.
- Do not use or store the device in a dusty or dirty environment. It might damage its detachable parts and electronic components.
- Do not store the device under extremely hot conditions. High temperatures can shorten the life of electronic devices, destroy batteries, and deform or melt some plastic parts.
- Do not store the device in places that are too cold. Otherwise, when the temperature rises, moisture that forms inside the device will damage the board.
- Do not throw, knock, or shake the device. Rough handling of equipment can destroy internal circuit boards and delicate structures.
- Do not clean the device with strong chemicals, detergents, or strong detergents.
- Do not apply the device with paint. Smudges might block the device and affect the operation.
- Do not throw the battery into the fire, or the battery will explode. Damaged batteries may also explode.

All of the above applies to your device, battery, and accessories. If any device is not operating properly, please take it to the nearest authorized service facility for repair.

## 10. Precautions for Outdoor Installation

According to the Enclosure Protection Class (IP code), the device is compliant to GB 4208-2008 standard, which is equivalent to IEC 60529:2001 degrees of protection provided by enclosures (IP Code).

IP Standard Test Method:

IP65: spray the device in all directions under 12.5L/min water flow for 3min, and the internal electronic function is normal.

IP65 is dustproof and able to prevent damage caused by water from nozzles in all directions from invading electrical appliances. It can be used in general indoor and sheltered outdoor environments. Installation in extreme weather conditions or direct exposure to sunlight and rain could damage the components of the device. Users may need to install the device under an awning (fig. 1) or face the side with an LED and function key downwards (fig. 2) to prevent malfunction.

IP67: the device is immersed in 1m deep water for 30 minutes, and the internal electronic function is normal.



Fig 1. Install under an awning



Fig 2. Install with LED and function key faced downwards