

Wireless 2-Input 0-5V ADC Sampling Interface

R718IA2 User Manual

Copyright©Netvox Technology Co., Ltd.

This document contains proprietary technical information which is the property of NETVOX Technology. It shall be maintained in strict confidence and shall not be disclosed to other parties, in whole or in part, without written permission of NETVOX Technology. The specifications are subject to change without prior notice.

Table of Content

1. Introduction.....	2
2. Appearance.....	3
3. Main Feature	3
4. Set Up Instruction	4
5. Data Report	5
5.1 Example of ReportDataCmd.....	5
5.2 Example of ConfigureCmd	6
5.3 Example for MinTime/MaxTime logic	7
6. Installation.....	9
7. Information about Battery Passivation.....	10
7.1 To determine whether a battery requires activation	10
7.2 How to activate the battery	10
8. Important Maintenance Instruction	11

1. Introduction

R718IA2 is a voltage detection device that is a Class A device based on the LoRaWAN open protocol and is compatible with the LoRaWAN protocol. R718IA2 will check the voltage of device regularly according to the configured time, and the ADC sampling voltage range is 0-5V.

LoRa Wireless Technology:

LoRa is a wireless communication technology famous for its long-distance transmission and low power consumption. Compared with other communication methods, LoRa spread spectrum modulation technique greatly extend the communication distance. It can be widely used in any use case that requires long-distance and low-data wireless communications. For example, automatic meter reading, building automation equipment, wireless security systems, industrial monitoring. It has features like small size, low power consumption, long transmission distance, strong anti-interference ability and so on.

LoRaWAN:

LoRaWAN uses LoRa technology to define end-to-end standard specifications to ensure interoperability between devices and gateways different manufacturers.

2. Appearance



3. Main Feature

- Adopt SX1276 wireless communication module.
- 2 sections of ER14505 battery in parallel (AA size 3.6V / section)
- 2-input voltage detection
- The base is attached with a magnet that can be attached to a ferromagnetic material object
- Protection level IP65/ IP67 (optional)
- Compatible with LoRaWAN™ Class A
- Frequency hopping spread spectrum.
- Applicable to third-party platforms: Actility/ThingPark, TTN, MyDevices/Cayenne
- Low power consumption and long battery life

Battery Life:

- Please refer to web: http://www.netvox.com.tw/electric/electric_calc.html
- At this website, users can find battery life time for variety models at different configurations.
 1. Actual range may vary depending on environment.
 2. Battery life is determined by sensor reporting frequency and other variables.

4. Set Up Instruction

On/Off

Power on	Insert batteries (User may need a screwdriver to open)
Turn on	Press and hold the function key for 3 seconds till the green indicator flashes once
Turn off (Restore to factory setting)	Press and hold the function key for 5 seconds till green indicator flashes 20 times
Power off	Remove Batteries
Note	<ol style="list-style-type: none"> 1. Remove and insert the battery, and the device is in turn-off state by default. 2. On/off interval is suggested to be about 10 seconds to avoid the interference of capacitor inductance and other energy storage components 3. In the first 5 seconds after power on, the device is in engineering test mode

Network Joining

Never join the network	<p>Turn on the device to search the network.</p> <p>The green indicator stays on for 5 seconds: success</p> <p>The green indicator remains off: fail</p>
Had joined the network (Not restore to the factory setting)	<p>Turn on the device to search the previous network.</p> <p>The green indicator stays on for 5 seconds: success</p> <p>The green indicator remains off: fail</p>
Fail to Join the Network	Suggest to check the device verification information on the gateway or consult your platform server provider.

Function Key

Press and hold for 5 seconds	<p>Restore to factory setting / Turn off</p> <p>The green indicator flashes 20 times: success</p> <p>The green indicator remains off: fail</p>
Press once	<p>The device is in the network: green indicator flashes once and sends a report</p> <p>The device is not in the network: green indicator remains off</p>

Sleeping Mode

The device is on and in the network	<p>Sleeping period: Min Interval</p> <p>When the reportchange exceeds setting value or the state changes, the device send a data report according to Min Interval.</p>
-------------------------------------	--

Low Voltage Warning

Low Voltage	3.2V
-------------	------

5. Data Report

The device will immediately send a version packet report and a data report including voltage.

The device sends data according to the default configuration before any other configuration.

Default Setting:

MaxTime: 0x384 (900s)

MinTime: 0x0384 (900s)

BatteryVoltageChange: 0x01 (0.1V)

ADCRawValueChange: 0x0064 (100mV)

Note:

1. The cycle of the device sending the data report is according to the default.
2. The interval between two reports must be the MinTime.
3. Please refer Netvox *LoRaWAN Application Command document* and *Netvox Lora Command Resolver*

<http://cmddoc.netvoxcloud.com/cmddoc> to resolve uplink data.

Data report configuration and sending period are as following:

Min Interval (Unit: second)	Max Interval (Unit: second)	Reportable Change	Current Change \geq Reportable Change	Current Change $<$ Reportable Change
Any number between 1~65535	Any number between 1~65535	Can not be 0	Report per Min Interval	Report per Max Interval

5.1 Example of ReportDataCmd

FPort: 0x06

Bytes	1	1	1	Var(Fix=8 Bytes)
	Version	DeviceType	ReportType	NetvoxPayloadData

Version– 1 byte –0x01——the Version of NetvoxLoRaWAN Application Command Version

DeviceType– 1 byte – Device Type of Device

The devicetype is listed in Netvox LoRaWAN Application Devicetype doc

ReportType – 1 byte –the presentation of the NetvoxPayloadData, according the devicetype

NetvoxPayloadData– Fixed bytes (Fixed =8bytes)

Tips

1. Battery Voltage:

The voltage value is bit 0 ~ bit 6, bit 7=0 is normal voltage, and bit 7=1 is low voltage.

Battery=0xA0, binary=1010 0000, if bit 7= 1, it means low voltage.

The actual voltage is 0010 0000 = 0x20 = 32, 32*0.1v =3.2v

2. Version Packet:

When Report Type=0x00 is the version packet, such as 0141000A0B202005200000, the firmware version is 2020.05.20

3. Data Packet:

When Report Type=0x01 is data packet.

Device	Device Type	Report Type	NetvoxPayloadData			
R718IA2	0x41	0x00	SoftwareVersion(1Byte) Eg.0x0A—V1.0	HardwareVersion (1Byte)	DateCode (4Bytes, eg0x20170503)	Reserved (2Bytes, fixed 0x00)
		0x01	Battery (1Byte, unit:0.1V)	ADCRawValue 1 (2Bytes,unit: 1mv)	ADCRawValue 2 (2Bytes,unit:1mv)	Reserved (3Bytes, fixed 0x00)

Uplink: 0141012404E20514000000

1st byte (01): Version

2nd byte (41): DeviceType 0x41, R718IA2

3rd byte (01): Report Type

4th byte (24): Battery 3.6v , 24 H_{ex}=36 D_{ec} 36*0.1v=3.6v

5th 6th byte (04E2): ADC Raw Value = 1250mV, 4E2 H_{ex}=1250 D_{ec}

7th 8th byte (0514): ADC Raw Value = 1300mV, 514 H_{ex}=1300 D_{ec}

9th ~ 11th byte (000000): Reserved

5.2 Example of ConfigureCmd

FPort: 0x07

Bytes	1	1	Var (Fix =9 Bytes)
	CmdID	DeviceType	NetvoxPayloadData

CmdID– 1 byte

DeviceType– 1 byte – Device Type of Device

NetvoxPayloadData– var bytes (Max=9bytes)

Description	Device	CmdID	Device Type	NetvoxPayLoadData					
Config ReportReq	R718IA2	0x01	0x41	MinTime (2bytes Unit: s)	MaxTime (2bytes Unit: s)	Battery Change (1byte Unit:0.1v)	ADCRaw ValueChange (2byte Unit:1mV)	Reserved (4Bytes,Fixed 0x00)	
Config ReportRsp		0x81		Status (0x00_success)			Reserved (8Bytes, Fixed 0x00)		
ReadConfig ReportReq		0x02		Reserved (9Bytes, Fixed 0x00)					
ReadConfig ReportRsp		0x82		MinTime (2bytes Unit: s)	MaxTime (2bytes Unit: s)	Battery Change (1byte Unit: 0.1v)	ADCRaw ValueChange (2byte Unit:1mV)	Reserved (4Bytes, Fixed 0x00)	

(1) Configure R718IA2 device parameter MinTime = 1min, MaxTime = 1min, BatteryChange = 0.1v, ADCRawValueChange=100mV

Downlink: 0141003C003C0100640000

Device Return:

81410000000000000000 (configuration success)

81410100000000000000 (configuration failure)

(2) Read R718IA2 device parameter

Downlink: 02410000000000000000

Device Return:

8241003C003C0100640000 (device current parameter)

5.3 Example for MinTime/MaxTime logic

Example#1 based on MinTime = 1 Hour, MaxTime= 1 Hour, Reportable Change i.e. BatteryVoltageChange=0.1V

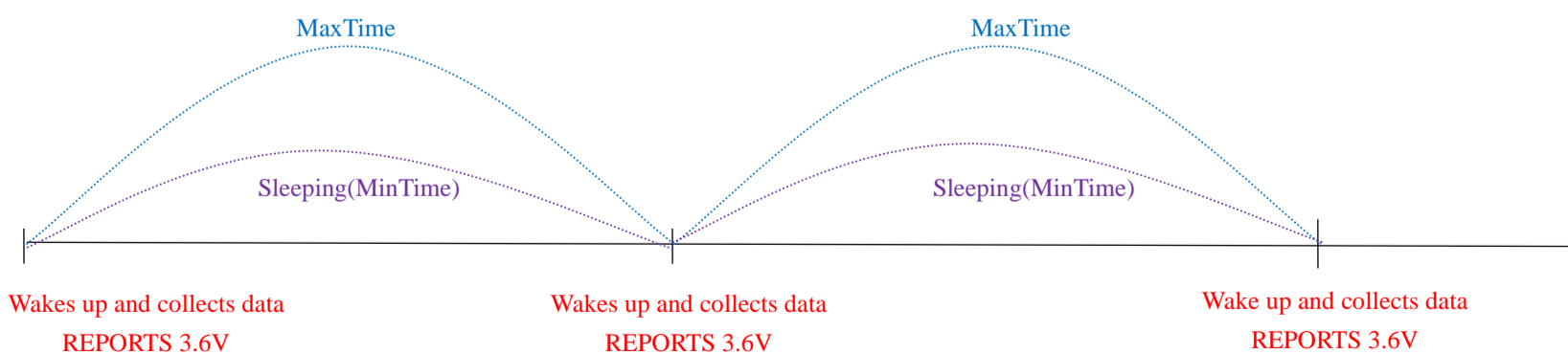

Note: MaxTime=MinTime. Data will only be report according to MaxTime (MinTime) duration regardless BatteryVoltageChange value.

Example#2 based on MinTime = 15 Minutes, MaxTime= 1 Hour, Reportable Change i.e. BatteryVoltageChange= 0.1V.

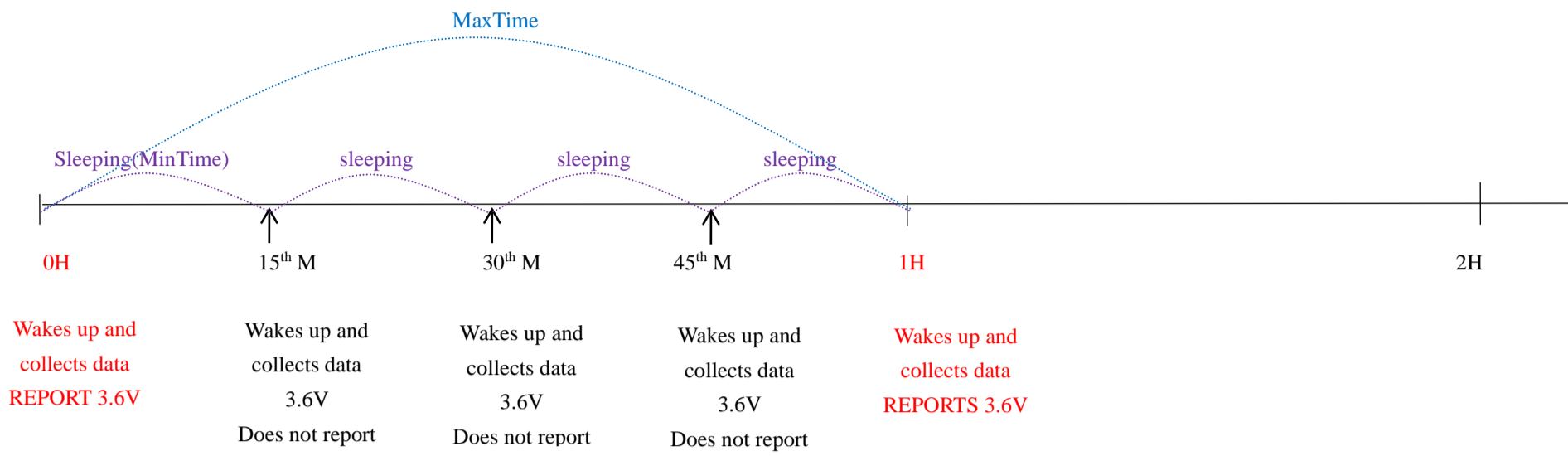

Example#3 based on MinTime = 15 Minutes, MaxTime= 1 Hour, Reportable Change i.e. BatteryVoltageChange= 0.1V.

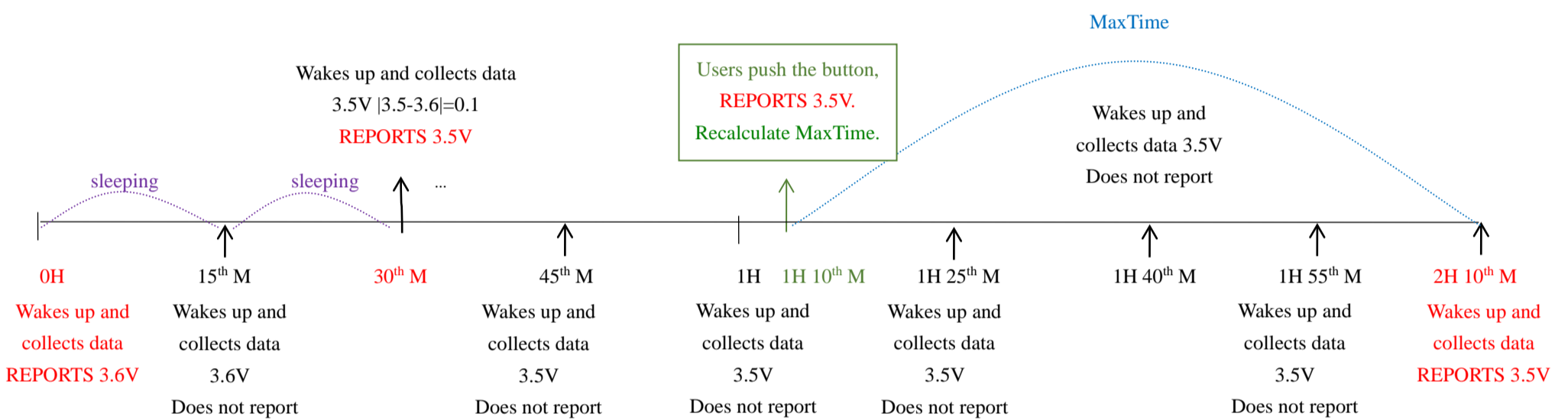

Notes :

- 1) The device only wakes up and performs data sampling according to MinTime Interval. When it is sleeping, it does not collect data.
- 2) The data collected is compared with the last data reported. If the data variation is greater than the ReportableChange value, the device reports according to MinTime interval. If the data variation is not greater than the last data reported, the device reports according to MaxTime interval.
- 3) We do not recommend to set the MinTime Interval value too low. If the MinTime Interval is too low, the device wakes up frequently and the battery will be drained soon.
- 4) Whenever the device sends a report, no matter resulting from data variation, button pushed or MaxTime interval, another cycle of MinTime/MaxTime calculation is started.

6. Installation

1. Wireless ADC Sampling Interface (R718IA2) has the built-in magnet (as the figure below). When installed, it can be attached to the surface of an object with iron which is convenient and quick. To make the installation more secure, use screws (purchased) to secure the unit to a wall or other surface (as the figure below).

Note:

Do not install the device in a metal shielded box or in an environment with other electrical equipment around it to avoid affecting the wireless transmission of the device.

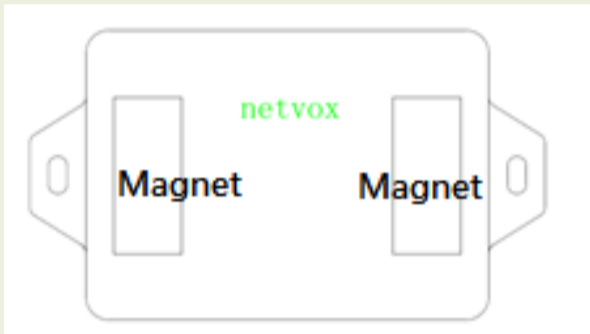

2. Connect the sampling line of the ADC sampling interface sensor to the transmitter according to the wiring method shown in figure. There are two connection modes, 2-wire and 3-wire.

3. When the ADC sampling interface sensor detects the current voltage according to the configured time or by pressing the button, it sends the data immediately

Wireless Sampling Interface (R718IA2)

It can also be applied to the following scenarios:

- Pressure transmitter
- Differential pressure transmitter
- Level transmitter

The transmitter with 0-5V output signal

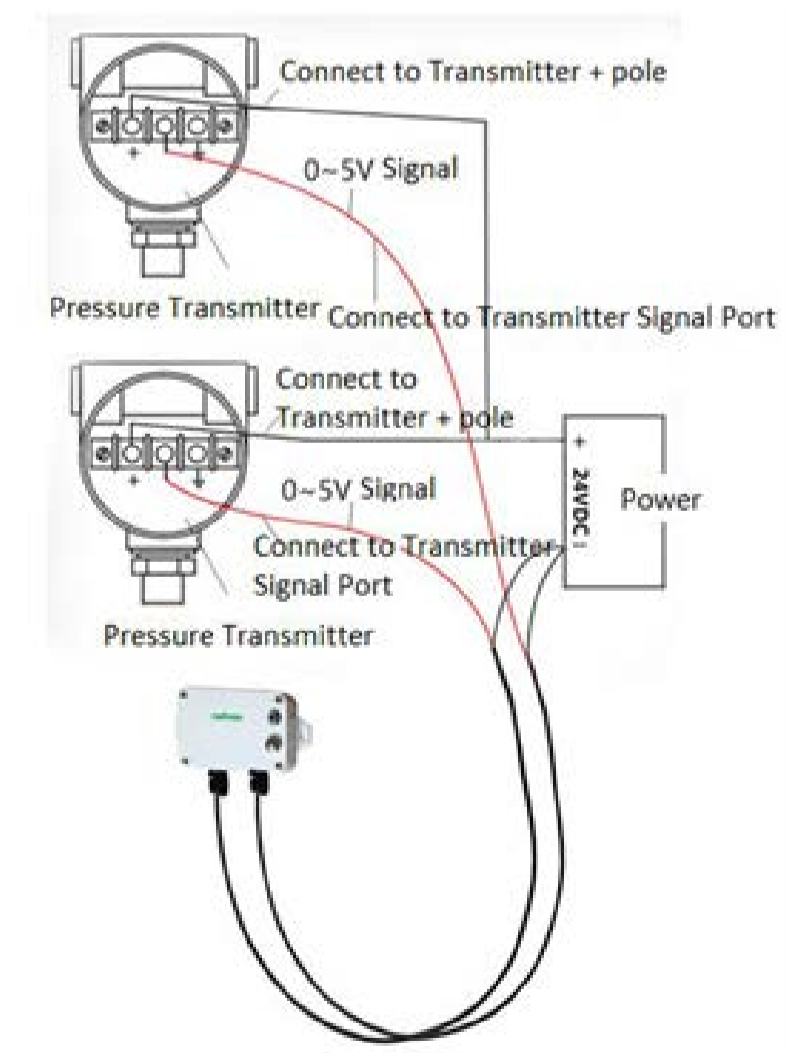

Fig. 2-wire System Example Diagram
(for wiring reference)

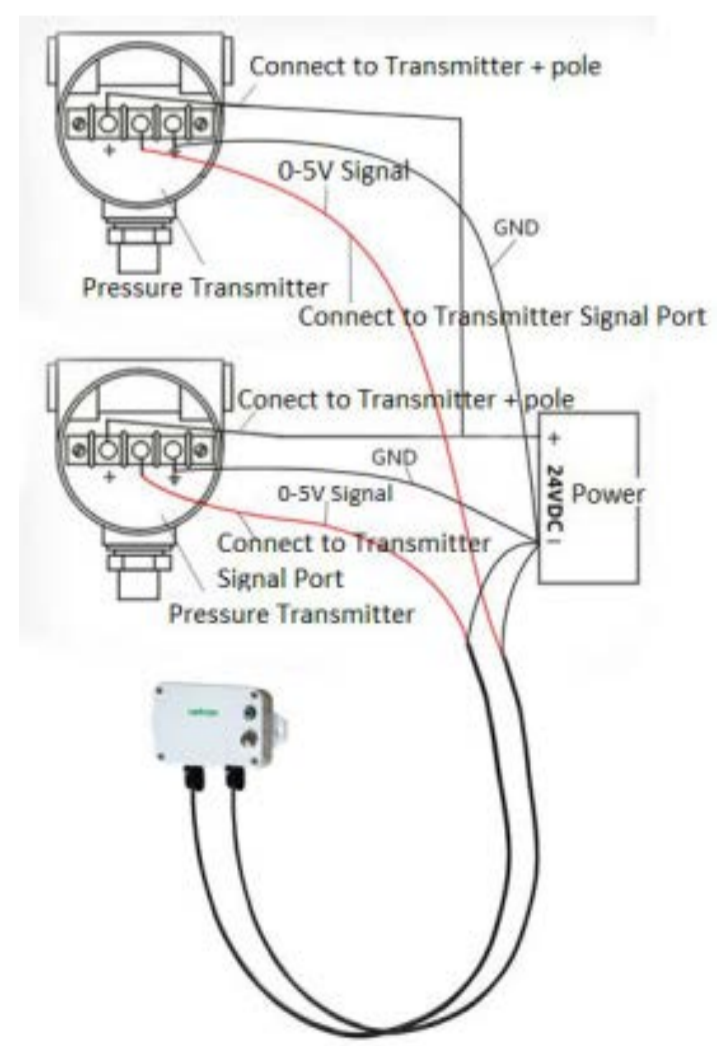

Fig. 3-wire System Example Diagram
(for wiring reference)

Note:

Please do not disassemble the device unless it is required to replace the batteries.

Do not touch the waterproof gasket, LED indicator light, function keys when replacing the batteries. Please use suitable screwdriver to tighten the screws (if using an electric screwdriver, it is recommended to set the torque as 4kgf) to ensure the device is impermeable.

7. Information about Battery Passivation

Many of Netvox devices are powered by 3.6V ER14505 Li-SOCl₂ (lithium-thionyl chloride) batteries that offer many advantages including low self-discharge rate and high energy density.

However, primary lithium batteries like Li-SOCl₂ batteries will form a passivation layer as a reaction between the lithium anode and thionyl chloride if they are in storage for a long time or if the storage temperature is too high. This lithium chloride layer prevents rapid self-discharge caused by continuous reaction between lithium and thionyl chloride, but battery passivation may also lead to voltage delay when the batteries are put into operation, and our devices may not work correctly in this situation.

As a result, please make sure to source batteries from reliable vendors, and it is suggested that if the storage period is more than one month from the date of battery production, all the batteries should be activated.

If encountering the situation of battery passivation, users can activate the battery to eliminate the battery hysteresis.

ER14505 Battery Passivation:

7.1 To determine whether a battery requires activation

Connect a new ER14505 battery to a resistor in parallel, and check the voltage of the circuit.

If the voltage is below 3.3V, it means the battery requires activation.

7.2 How to activate the battery

- a. Connect a battery to a resistor in parallel
- b. Keep the connection for 5~8 minutes
- c. The voltage of the circuit should be ≥ 3.3 , indicating successful activation.

Brand	Load Resistance	Activation Time	Activation Current
NHTONE	165 Ω	5 minutes	20mA
RAMWAY	67 Ω	8 minutes	50mA
EVE	67 Ω	8 minutes	50mA
SAFT	67 Ω	8 minutes	50mA

Note:

If you buy batteries from other than the above four manufacturers, then the battery activation time, activation current, and required load resistance shall be mainly subject to the announcement of each manufacturer.

8. Important Maintenance Instruction

Kindly pay attention to the following in order to achieve the best maintenance of the product:

- Keep the equipment dry. Rain, moisture and various liquids or water may contain minerals that can corrode electronic circuits. In case the device is wet, please dry it completely.
- Do not use or store in dusty or dirty areas. This way can damage its detachable parts and electronic components.
- Do not store in excessive heat place. High temperatures can shorten the life of electronic devices, destroy batteries, and deform or melt some plastic parts.
- Do not store in excessive cold place. Otherwise, when the temperature rises to normal temperature, moisture will form inside which will destroy the board.
- Do not throw, knock or shake the device. Treating equipment roughly can destroy internal circuit boards and delicate structures.
- Do not wash with strong chemicals, detergents or strong detergents.
- Do not paint the device. Smudges can make debris block detachable parts up and affect normal operation.
- Do not throw the battery into the fire to prevent the battery from exploding. Damaged batteries may also explode.

All the above suggestions apply equally to your device, batteries and accessories.

If any device is not operating properly, please take it to the nearest authorized service facility for repairing.