

Wireless Temperature Sensor - PT1000 Absorption Probe

Wireless Sensor Network Based on LoRa Technology



R718B222

Data Sheet

Copyright©Netvox Technology Co., Ltd.

This document contains proprietary technical information which is the property of NETVOX Technology. It shall be maintained in strict confidence and shall not be disclosed to other parties, in whole or in part, without written permission of NETVOX Technology. The specifications are subject to change without prior notice.

Introduction

R718B222 is a device used to detect object temperature. It can connect PT1000 platinum thermistor and join the gateway to display the collected data in the gateway. It adopts SX1276 wireless communication module.

Main Characteristic

- Adopt SX1276 wireless communication module
- One-gang PT1000 platinum thermal resistance detection
- Temperature range of -50 °C to 180°C
- When installing the adsorption type PT1000, the magnet must be pressed tightly, the contact surface must be flat and wiped clean, and heat-conductive grease is added to the object to be tested to make the heat transfer effect better
- 2 section of ER14505 lithium battery in parallel (AA size 3.6V / section)
- IP rating: Main body IP65/ IP67 (optional), sensor IP67
- The base is attached with a magnet that can be attached to a ferromagnetic material object
- Compatible with LoRaWAN™ Class A
- Frequency hopping spread spectrum technology
- Configuration parameters can be configured through a third-party software platform , data can be read, and alerts can be set through SMS text and e-mail (optional)
- Applicable to third-party platforms: Actility / ThingPark, TTN, MyDevices / Cayenne

Note: Battery life is determined by the sensor reporting frequency and other variables, please refer to http://www.netvox.com.tw/electric/electric_calc.html

On this website, users can find battery life of various models in different configurations.

Wireless Temperature Sensor - PT1000 Absorption Probe

Application

- Temperature measuring device
- Thermodynamic system device
-

Dimension

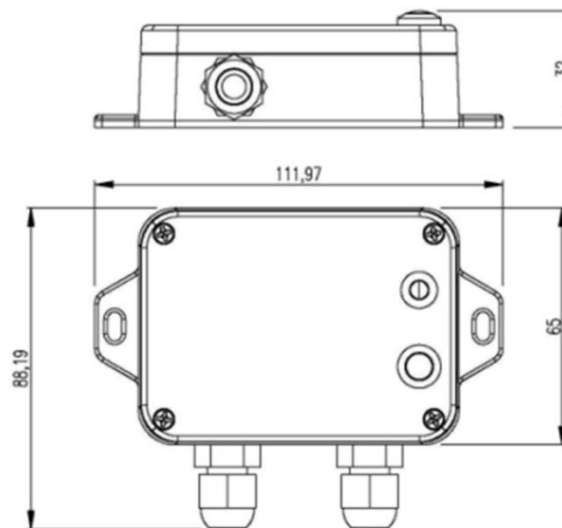

Electric

Input Power	2 x ER14505 lithium batteries (3.6V 2400mah/section)
Operating Voltage	DC 3.1V to 3.65V
Battery Life	5 years (Conditions: ambient temperature 25 °C, 15 min report once, TX power = 20dBm, LoRa spreading factor SF = 10)
Standby Current	25uA
Wakeup Current	9.94mA (Typical value) Wakeup current range 0.8mA-20 mA * When not transmitting /receiving LoRa data
Low Battery Voltage Threshold	3.2V
Battery Measurement Accuracy	±0.1V

Wireless Temperature Sensor - PT1000 Absorption Probe
Module-R100H

Wake-up Current	(0.8mA - 8mA)/3.3V
RF Receiving Current (max)	11mA/3.3V
RF Transmitting Current (max)	120mA/3.3V

*Specific electrical characteristics will vary depending on the power supply voltage

Frequency

Frequency Range	863MHz-928MHz 470MHz-510MHz
Power Output	US915 20dbm; AS923 16dbm; AU915 20dbm; CN470 19.15dbm; EU868 16dbm; KR920 14dbm; IN865 20dbm;
Receiving Sensitivity	-136 dBm (LoRa, Spreading Factor=12, Bit Rate = 293bps); -121 dBm (FSK, Frequency deviation=5kHz, Bit Rate=1.2kbps)
Antenna Type	Built-in antenna
Communication Distance	Up to 10 km (visible linear obstacle-free transmission distance, actual transmission distance depends on the environment)
Data transfer Rate	0.3kbps ~ 50kbps (LoRaWAN) 1.2kbps ~ 300kbps (FSK)
Modulation System Mode	LoRa/ FSK (Note: choose one of them)
Supportable LoRaWAN Band	EU863-870,US902-928,AU915-928,KR920-923,AS923-1, AS923-2, AS923-3,IN865-867,CN470-510 (Note: optional, to be done in the factory configuration)

Wireless Temperature Sensor - PT1000 Absorption Probe
PT1000 Platinum Thermal Resistance Specification

PT1000 Temperature Range	-50°C to 180°C
Measurement Range & Accuracy	<p>The host body and PT1000 sensor are in the same temperature range: Temperature range: $0^{\circ}\text{C} \leq t \leq 55^{\circ}\text{C}$, Accuracy: $\pm 1^{\circ}\text{C}$</p> <p>The host body and PT1000 sensor are in the different temperature ranges:</p> <p>Temperature range T1: $0^{\circ}\text{C} \leq T1 \leq 55^{\circ}\text{C}$ (Host body) Temperature range T2: $-50^{\circ}\text{C} \leq T2 < 0^{\circ}\text{C}$ (Sensor) Accuracy: $\pm\{(0.15 + 0.002 * T2) + 1.5\}^{\circ}\text{C}$</p> <p>Temperature range T1: $0^{\circ}\text{C} \leq T1 \leq 55^{\circ}\text{C}$ (Host body) Temperature range T2: $55^{\circ}\text{C} < T2 \leq 180^{\circ}\text{C}$ (Sensor) Accuracy: $\pm\{(0.15 + 0.002 * T2) + 0.8\}^{\circ}\text{C}$</p>
Wire Length	2m (default)
Probe Dimension	15mm in diameter, absorption probe, NdFeB magnet
Wiring	2 cores
Probe IP Rating	IP67
ROHS Standard	Meet ROHS standards

Physical

Host Body Dimension	L: 112 mm*W: 88.19 mm*H: 32 mm
Ambient Temperature Range	-20 °C to 55°C
Ambient Humidity Range	<90% RH (No condensation)

Wireless Temperature Sensor - PT1000 Absorption Probe
R718B Series Type

Model		Temperature Range	Probe Type	Probe IP Rating
R718B120	One-gang	-70° to 200°C	Round head type	IP67
R718B220	Two-gang			
R718B121	One-gang		Needle type	
R718B221	Two-gang			
R718B122	One-gang	-50° to 180°C	Absorption Probe	
R718B222	Two-gang			
R718B140	One-gang	-40° to 375°C	Round head type	IP50
R718B240	Two-gang			
R718B141	One-gang		Needle type	
R718B241	Two-gang			
R718B150	One-gang	-40° to 500°C	Round head type	
R718B250	Two-gang			
R718B151	One-gang		Needle type	
R718B251	Two-gang			